

Technical Standard L3

Measuring Air Permeability in the Envelopes of Complex Buildings Fan Pressurisation Method

(September 2021) Issue 1

This document provides the technical standard to be followed for the testing of buildings that are considered complex. A complex building is defined as one which cannot be tested in the entirety with a single test.

This testing described in this standard is fundamentally based on *ISO 9972:2015 Thermal performance of buildings – ‘Determination of air permeability of buildings - Fan pressurization method’* though the guidance is provided by the Air Tightness Testing & Measurement Association.

This Technical Standard provides detailed guidance and clarification of the above standard to ensure consistency by testing companies.

Guidance for test procedures for the testing of buildings that are simple is provided within companion reference document ATTMA Technical Standard L1.

Guidance for test procedures for the testing of buildings that are non-simple is provided within companion reference document ATTMA Technical Standard L2.

Guidance for test procedures for the testing of low energy buildings is provided within companion reference document ATTMA Technical Standard L4

Building Type	Test Standard
Buildings - Single Fan	TSL1
Buildings - Multiple Fan	TSL2
Building Extensions	TSL2
Permanently Compartmentalised	TSL2 - All compartments simultaneously TSL3 - Compartments as zones
High Rise	TSL3
Phased Handover	TSL3
Student Accommodation	TSL1 - Whole building TSL2 - Whole building TSL3 - High rise, phased handover
Sheltered Housing	TSL1 - residential units, whole building TSL2 - communal areas, whole building
Apartments Over Retail	TSL1 - Apartments, retail TSL2 - Large retail
Shell and Core	TSL1 TSL2 TSL3
Low Energy Buildings	TSL4

Contents

Section 1 - Introduction	4
1.1 What is Air Tightness Testing?	4
1.2 How is Air Tightness Measured?	4
1.3 Presentation of Results	4
1.4 Who is Authorised to Test?	4
1.5 Air Tightness & Ventilation	5
1.6 Best Practice Air Permeability	5
Section 2 – Pre-Test Requirements	7
2.1 Building Envelope Calculations	7
2.2 Confirmation of Calculations	14
Section 3 - Test Set Up Methods	15
3.1 Fan System Selection	15
3.2 Fan Flow Rate	15
3.3 Installation Location	15
3.4 Multiple Occupancy Buildings	16
3.5 Buildings with Multiple Storeys	17
3.6 Permanently Compartmentalised Buildings	18
3.7 Phased Handover Buildings	23
3.8 High Rise Buildings	27
3.9 Special Cases	38
3.10 Building Preparation	40
Section 4 – Site Test Procedure	44
4.1 Test Direction	44
4.2 Test Procedure Detail	44
4.3 Test Results	48
Section 5 - Test Report	49
5.1 Companies Operating Within a Competent Person Scheme	49
5.2 Companies which do not Operate within a Competent Person Scheme	50
Appendix A - Equations and Corrections	52
Appendix B – Technical Validity	57
Appendix C - Test Equipment Requirements	59
Appendix D - Equivalent Leakage Area (ELA)	61
Appendix E – Software verification process	62
Appendix F – Checklists	66

Section 1 - Introduction

1.1 What is Air Tightness Testing?

Air tightness testing is the process of measuring the amount of conditioned (heated or cooled) air entering or exiting a building through uncontrolled infiltration.

1.2 How is Air Tightness Measured?

A calibrated fan is installed into the external envelope of the building and supplies air into, or extracts air out of, the property creating a controlled building pressure differential. The tester uses calibrated equipment and calculates an air flow into, or out of, the property. In simple terms, the amount of air going into, or out of the property when the building is subject to a pressure differential is the amount of 'air leakage'.

1.3 Presentation of Results

The result can be presented in several ways:

1. **Air Leakage**, known as ' Q_{pr} ', is the amount of air entering or exiting the building at a given pressure.
 - a. In most countries, Q_{50} is used to denote the air leakage at a building pressure differential of 50 Pa. Units are $m^3.h^{-1}$ @ 50 Pa.
2. **Air Permeability**, known as ' AP_{pr} ', is the amount of air leakage divided by the internal envelope area of the building.
 - a. In most countries, AP_{50} is used to denote the air permeability at a building pressure differential of 50 Pa. Units are $m^3.h^{-1}.m^{-2}$ @ 50 Pa.
3. **Air Changes per Hour**, known as ' N_{pr} ', is the amount of air leakage divided by the internal volume of the building.
 - a. In most countries, N_{50} is used to denote the air changes per hour at a building pressure differential of 50 Pa. Units are $m^3.h^{-1}.m^{-3}$ @ 50 Pa.

1.4 Who is Authorised to Test?

For a testing organisation to show compliance with this standard they shall carry out their testing in an equitable manner and must remain independent of companies involved in the construction of the buildings they test. They must also have suitable third party monitoring systems in place and this is demonstrated by either:

1. having an active registration with a nationally recognised Competent Persons Scheme (CPS) for building air tightness testing and are deemed qualified by the scheme to test buildings of this level.
or
2. holding accreditation specifically for this test standard in line with ISO/IEC 17025:2017, or later.

1.5 Air Tightness & Ventilation

A common myth is that very low air tightness can cause building sickness and poor air quality, however, it is inadequate ventilation that causes poor air quality. It is important to match the air tightness testing targets and result with adequate means of ventilation.

This standard does not give guidance on adequate ventilation levels. Guidance can be taken from local Building Regulations requirements.

High air permeability results (results greater than $5 \text{ m}^3 \cdot \text{h}^{-1} \cdot \text{m}^{-2}$ @ 50 Pa) will allow much more freedom with the choice of ventilation due to natural air infiltration. It should be noted however, that natural infiltration can include volatile organic compounds (VOCs) (particularly in cities and urban environments) and other impurities and therefore is not considered a clean source of 'fresh air'. It should also be noted, advanced mechanical ventilation systems, such as heat recovery systems, may use much more energy than designed, and may not adequately heat a building with excess air leakage. Mechanical ventilation systems, particularly those with heat recovery abilities, could require more maintenance and operate at an increased noise level as a consequence of high air permeability results.

1.6 Best Practice Air Permeability

Table 1 highlights guidance on what is considered 'good practice' for residential buildings.

It shall be noted however that the below figures may not apply to all situations. In the case of doubt, advice shall be sought.

Table 1 – Best Practice Air Permeability Against Ventilation Strategy

Ventilation Strategy	Best Practice Air Permeability (AP_{50})
Background ventilation and/or intermittent extractors	3.0 – 5.0
Passive Stack	3.0 – 5.0
Continuous Mechanical Ventilation	2.0 – 4.0
Continuous Mechanical Ventilation with Heat Recovery	0.2 – 2.0
Other	Seek Specialist Advice

Table 2 highlights guidance on what is considered ‘good practice’ for non-dwellings.

It shall be noted however that the below figures may not apply to all situations. In the case of doubt, advice shall be sought.

Table 2 – Best Practice Air Permeability Against Building Type

Building Type	Best Practice Air Permeability (AP_{50})
Archive	< 0.50
Care Home	< 3.00
Cold Store	< 0.30
Community Building	< 3.00
Data Centre	< 3.00
Educational	< 4.00
Hospitals	< 3.00
Hotels	< 4.00
Laboratory	< 3.00
Leisure	< 3.00
Medical	< 3.00
Modular Building	< 3.00
Museum	< 1.00
Office	< 4.00
Place of Worship	< 4.00
Prison	< 3.00
Retail	< 3.00
Student accommodation	< 3.00
Warehouse	< 3.00

Section 2 – Pre-Test Requirements

Liaison shall be made with the client over the date and time of the test procedure. The client shall be made fully aware of the nature of the test and the degree of disruption that it may cause to construction works and/or operation of the building, however minor these are.

The test can be affected by extremes of weather (wind speed, internal/external temperature differential). Weather forecasts shall be checked prior to the proposed test date and if inclement weather is predicted, re-scheduling may be necessary.

There may be occasions when the building needs to be tested in conditions that are less than ideal and under these circumstances this must be clearly identified in the test report. However, if tests need to be carried out during periods of 'fresh' ($\geq 6 \text{ m.s}^{-1}$) wind speeds, the zero flow pressure differences could be outside the acceptable range for a valid test as stated [Appendix B](#). In such circumstances the result may not be reflective of the actual performance of the building.

2.1 Building Envelope Calculations

The calculation of the building envelope is one of the most important parts of the test, as an incorrect envelope calculation will result in an incorrect result, even if the test was carried out without any issues.

The building envelope calculation is defined as the boundary or barrier separating the inside of the building or part of the building subject to the test from the outside environment or another building or another part of the building.

The building envelope shall normally be measured along the line of the element bordering the internal volume (as defined within BS EN ISO 9972:2015). Areas are measured as flat, *i.e. no allowance is made for undulating profiles such as profiled cladding or textures to wall components.*



The extent of the building to be tested must be confirmed. This will reflect the extent of the 'conditioned space' within the building *i.e. areas within the internal volume of a building that are directly or indirectly heated or cooled.*

Table 3 indicates when building elements must either be included or excluded from the building envelope calculations.

When the building is permanently compartmentalised the envelope area shall be calculated for the building as whole.

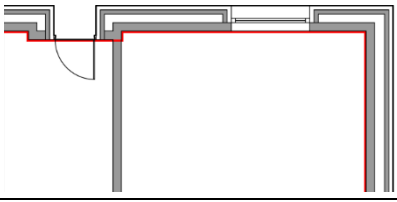
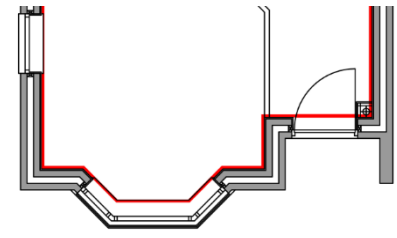
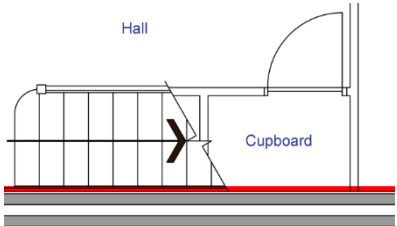
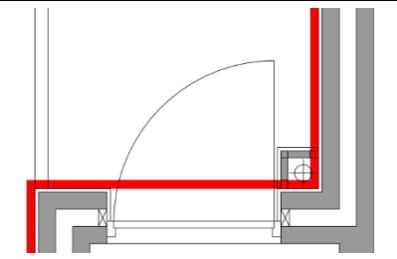
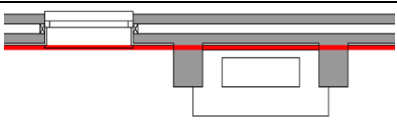
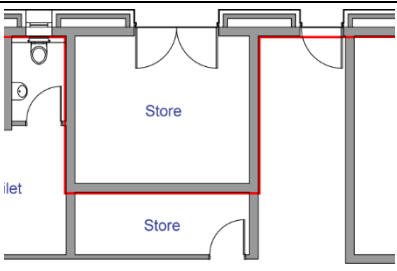
Table 3 – Air Permeability and Building Elements

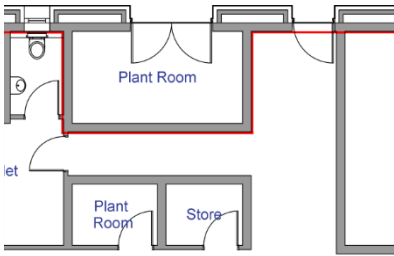
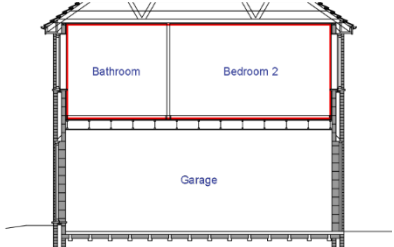
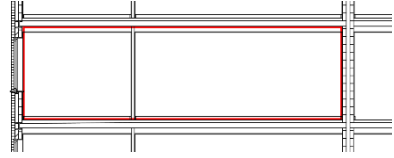
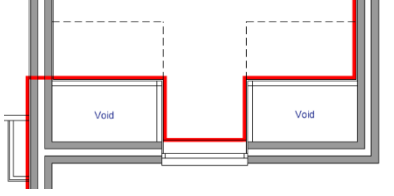
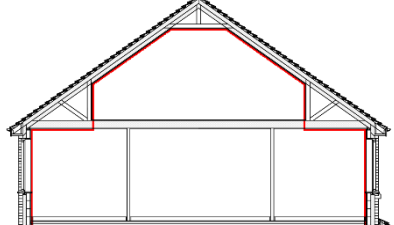
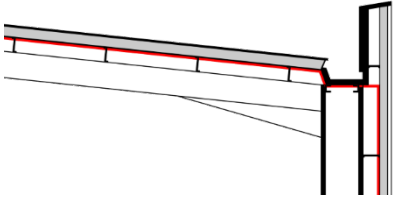
Element	
<p>Door and window reveals</p> <p>Exclude the area of door and window reveals. Measure the area as a flat surface and as a continuation of the wall. If the wall steps inwards so that there is a porch then the air barrier must be taken around this wall internally.</p>	
<p>Bay windows</p> <p>Include the area of bay windows when they have a floor area level with the storey floor level, before any furniture or fittings are installed, or there are steps to walk into them.</p>	
<p>Cupboards</p> <p>Include the area of cupboards within the building envelope calculation. This includes cupboards under stairs. For external stores please see below.</p>	
<p>Boxing</p> <p>Include the area of boxing within the building envelope calculation. Vanity units, which are typically found in bathrooms, are to be included within the building envelope calculation in the same manner as boxing.</p>	
<p>Skirting boards, architrave etc.</p> <p>Exclude the area of skirting boards, architrave and other wall fittings from the building envelope calculation and measure the wall as a flat surface.</p>	
<p>Fireplaces</p> <p>Exclude the area of fireplaces from the building envelope calculation. Measure the area as a flat surface and as a continuation of the wall.</p>	
<p>Garages and external stores</p> <p>Exclude the area of garages and external stores from the building envelope area calculation. Conditioned spaces that are either above or below must have the envelope area taken to the opposite side of the floor void or slab to the garage or external store. Include stores that are accessed from within the conditioned spaces.</p>	

<p>Plant rooms</p> <p>Where plant rooms are either enclosed by conditioned space or on a plant deck open to the conditioned space include them as conditioned space.</p> <p>Where plant rooms are on the perimeter of the envelope exclude them as unconditioned space and if there is any conditioned space above start the building envelope calculation from the top of the floor void.</p>	
<p>Floor voids</p> <p>Include floor voids where they adjoin two conditioned storeys.</p> <p>Exclude floor voids where they adjoin a single conditioned storey and start the envelope area on the conditioned storey</p>	
<p>Suspended ceilings</p> <p>Include the area above suspended ceilings and take the line of the building envelope to the underside of the solid floor slab.</p>	
<p>Roof voids and dormer windows</p> <p>Exclude the area of roof voids from the building envelope calculation as unconditioned space.</p> <p>Include the area of dormer windows in the building envelope calculation as conditioned space.</p>	
<p>Attic/loft space</p> <p>Include attic or loft spaces if a conditioned roof construction with openable loft hatch or if accessed by a door that is not weather resistant.</p> <p>Exclude attic or loft spaces if an unconditioned roof construction or not accessible via a loft hatch or a door.</p>	
<p>Parapets</p> <p>Exclude the area of parapets and continue the envelope area along the line of the roof or gully to the wall.</p>	
<p>Profiled Cladding and Roof Liners</p> <p>Exclude the area of the undulations in profiled cladding and roof liners and treat the area as flat along the conditioned side of the element.</p>	

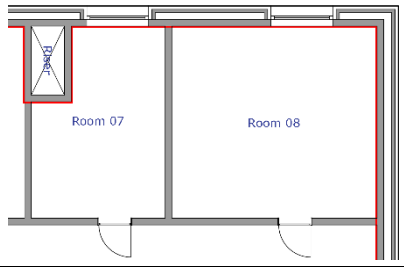
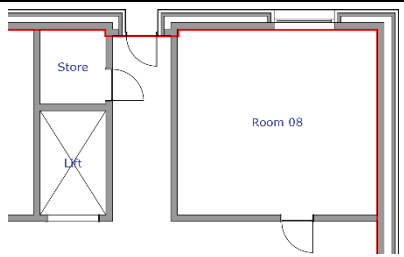
<p>Service Risers</p> <p>For each storey that service risers are enclosed by conditioned space include them as conditioned space. For each storey that service risers are on the perimeter of the envelope exclude them as unconditioned space.</p>	
<p>Lift Shafts</p> <p>For each storey that lift shafts are enclosed by conditioned space include them as conditioned space. For each storey that lift shafts are on the perimeter of the envelope exclude them as unconditioned space.</p>	

2.1.1 Multiple Building Elements

In the example below the boiler room, switch room and lifts are excluded from the envelope area calculation because they are on the perimeter and the service risers adjoining these are included in the envelope area calculation as they are not on the perimeter.

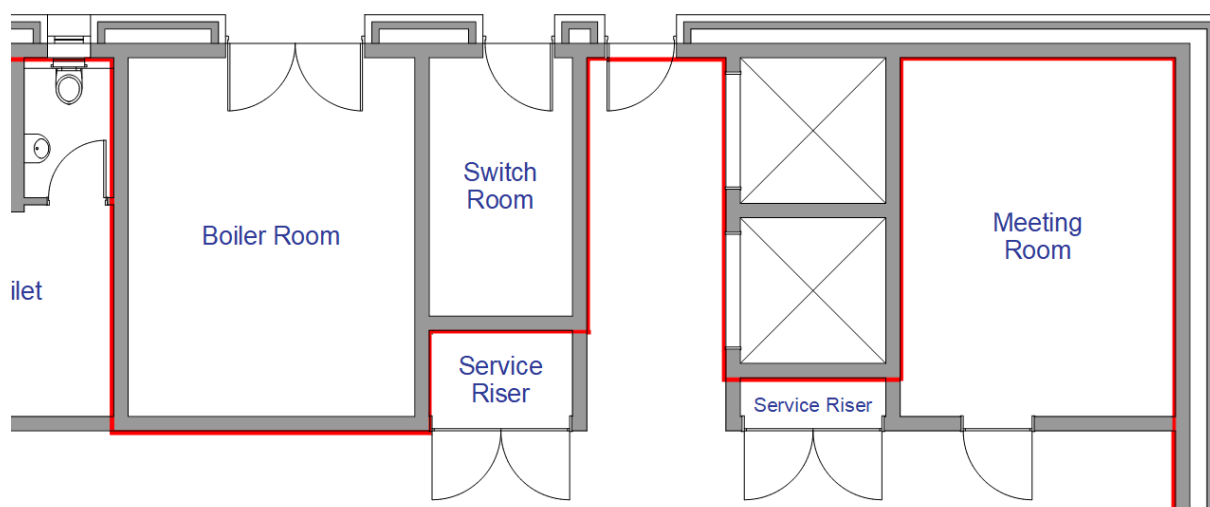

2.1.2 High Rise Buildings

When individual storeys are to be tested in high-rise buildings, as detailed in [Section 3.5](#), the areas adjoining adjacent storey are to be excluded from the building envelope area calculation for each storey. The wall area of stairwells that are not included within the test area of a storey to be excluded from the building envelope area calculation.

2.1.3 Permanently Compartmentalised Buildings

When the building is permanently compartmentalised the envelope area shall be calculated for the building in its entirety. When individual compartments are to be tested, as detailed in [Section 3.6](#), the areas adjoining adjacent compartments are to be excluded from the building envelope area calculation for each compartment.

2.1.4 Phased Handover Buildings

When the building is phased handover the envelope area shall be calculated for the building in its entirety. Each phase of the development will also require an envelope area where the areas adjoining adjacent phases are to be excluded from the building envelope area calculation for each phase. Further details can be found in [Section 3.7](#).

2.1.5 Example Building Envelope Calculation

Floor Plans

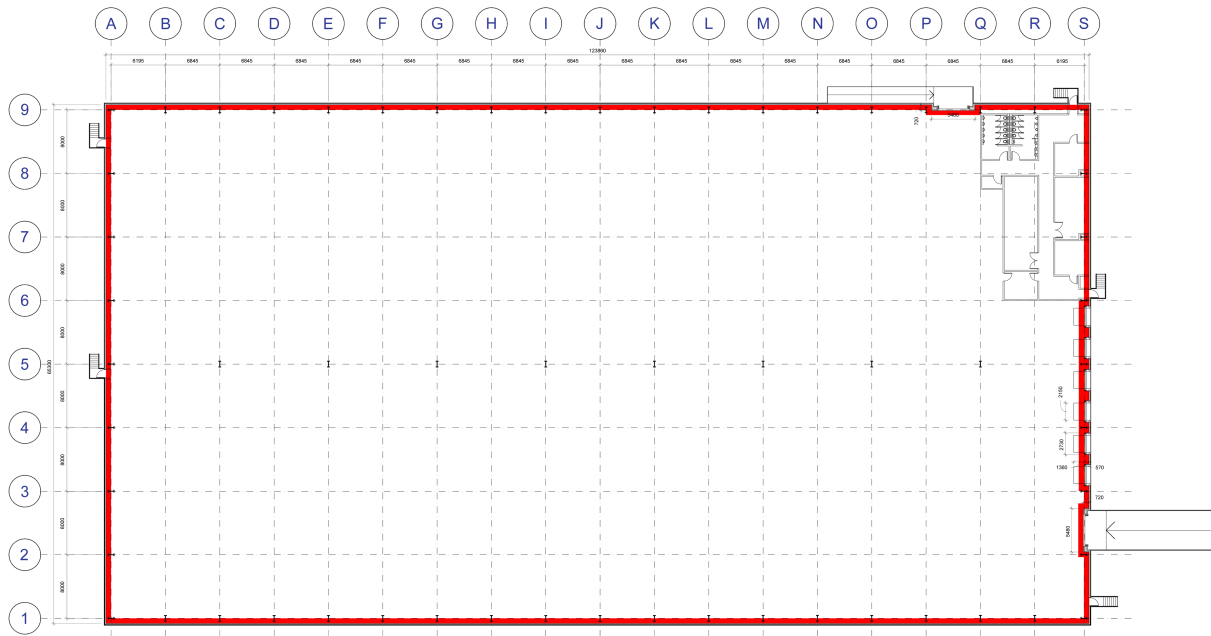

Sections

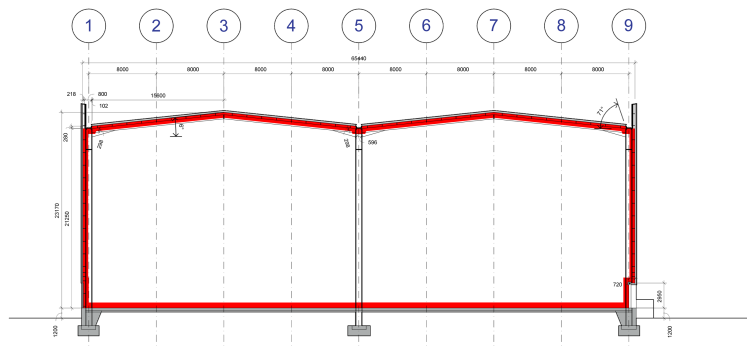
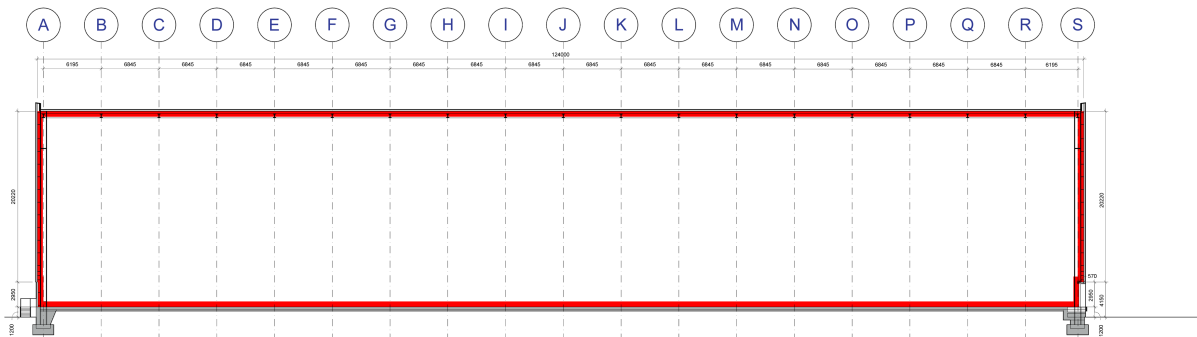

3D Model of Building Envelope Area

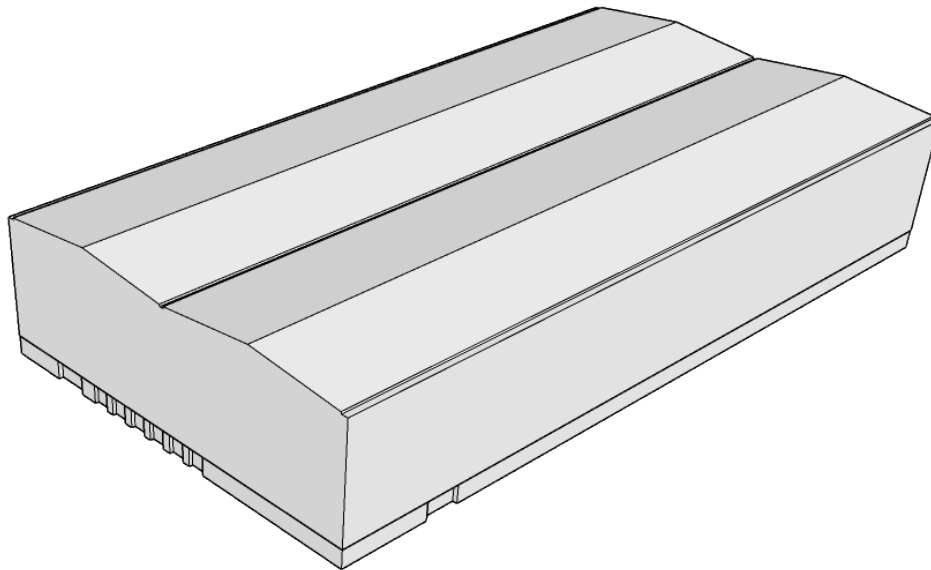

Building Envelope Calculation		
Floor Area		
Area including the step out		= 65.44 x 124 = 8,114.56 m ²
Total		= 8,114.56 m ²
Wall Area		
Area from warehouse floor to step out	Perimeter	= (65.3 + 123.86) x 2 = 189.16 x 2 = 378.32 m
	Area	= 378.32 x 2.95 = 1,116.044 m ²
Area from step out to gulley	Perimeter	= (65.44 + 124) x 2 = 189.44 x 2 = 378.88 m
	Area	= 378.88 x 18.3 = 6,933.504 m ²
Gulley to roof pitch (4)	Gable End	= (15.6 + 15.6 + 0.102) x 0.28 = 31.302 x 0.28 = 8.765 m ²
Roof pitch (4)	Gable End	= 15.6 x 1.64 = 25.584 m ²
Shutter door (2)	Side Walls	= (0.72 x 2.95) x 2 = 2.124 x 2 = 4.248 m ²
Dock shutter doors (6)	Side Walls	= (0.57 x 2.95) x 2 = 1.6815 x 2 = 3.363 m ²
Total		= 1,116.044 + 6,933.504 + (4 x 8.765) + (4 x 25.584) + (2 x 4.248) + (6 x 3.363) = 1,116.044 + 6,933.504 + 35.06 + 102.336 + 8.496 + 20.178 = 8,215.618 m ²
Roof Area		
Gulley flat area		= (0.218 + 0.8 + 0.596 + 0.8 + 0.218) x 124 = 2.632 x 124 = 326.368 m ²
Gulley pitch (4)		= .298 x 124 = 36.952 m ²
Pitched roof (4)		= (15.6 / cos(6°)) x 124 = 15.686 x 124 = 1,945.064 m ²
Total		= 326.368 + (4 x 36.952) + (4 x 1,945.064) = 326.368 + 147.808 + 7,780.256 = 8,254.432 m ²
Envelope Area		= 8,114.56 + 8,215.618 + 8,254.432 = 24,584.61 m ²

2.2 Confirmation of Calculations

The building envelope can be calculated from dimensioned drawings. If the building envelope is calculated using dimensioned drawings it is essential to verify the calculation on-site, using 2 or more 'reference check points' to confirm that the dimensions are accurate. The drawings used for the measurement must reflect the dimensions of the completed building.

An evaluation of the building or test area volume must be made prior to the test being undertaken. The necessary fan flow required to undertake the test shall be calculated from this figure.

The calculated building envelope will be referred to in subsequent data analysis and test reports and/or Lodgement Certificates.

Section 3 - Test Set Up Methods

3.1 Fan System Selection

The fan system will generally consist of one unit located within an external opening to the building envelope, or area under test. Adequate fan capacity must be available to undertake the test which will be established from the target specification, and the building envelope calculation.

The fan pressurisation system and associated equipment utilised must be calibrated in accordance with national standards, must be within accepted calibration periods and must be used within calibrated ranges (see [Appendix C](#)).

Care shall be taken when choosing a measurement system such that the system is relatively unaffected by irregular air entry conditions (wind velocities and local obstructions) and that there is stability in the measurement system. The proximity of local obstructions can cause inaccuracies. The proximity of multiple fan pressurisation systems can also cause inaccuracies.

3.2 Fan Flow Rate

The fan flow rate must be more than that required to pressurise or depressurise the building to greater than +/-55 Pa.

3.3 Installation Location

From information available, and through liaison with the client, the location for the installation of the fan pressurisation system should be established prior to the test date when testing large buildings (buildings with a building envelope greater than 750 m²). Several issues must be considered:

1. Access for fan pressurisation system to be delivered and installed.
2. Air flow restrictions in front of and around fans. A clear opening is preferred.
3. Any electrical power supplies which may be necessary.
4. Local restrictions, *e.g. noise, working hours etc.*
5. Acceptable route for the air to flow from the fans to achieve a uniform pressure throughout the building.

3.4 Multiple Occupancy Buildings

In some instances it may not be readily apparent how the building should be tested and guidance is provided below as to how such buildings may be tested.

3.4.1 Student Halls

The air tightness tests for Halls of residence must be undertaken to test the whole of the building envelope unless the building is deemed to fall within the criteria for high-rise as defined in [Section 3.6](#) where further guidance is provided.

Where halls of residence are split into clusters the air tightness test must be undertaken to test the whole of the building envelope unless the clusters fall within the criteria for a phased handover development as defined in [Section 3.8](#) where further guidance is provided.

3.4.2 Sheltered Housing

Some residential buildings such as sheltered housing provide independent living accommodation together with associated facilities such as communal areas and offices. There is usually no distinction between the areas with common rooms interspersed between residential units. When the residential units have individual energy assessment they must be tested as individual units and the remaining common areas and associated facilities are to be tested separately.

Where there are no residential units the air tightness test must be to the whole of the building envelope. This will include testing into each of the rooms by opening the doors.

3.4.3 Apartments Over Retail

Many buildings are now constructed with residential accommodation above ground floor retail units. In such instances there is typically a clearly defined boundary between the different types of use. They are usually separated by solid floor slab and served by independent entrances. When the residential units have an individual energy assessment they must be tested as individual units and the remaining common areas and associated facilities are to be tested separately. When the building has a single energy assessment the air tightness test must be to the whole of the building envelope.

3.5 Buildings with Multiple Storeys

It can sometimes be difficult to achieve a uniform building pressure across buildings with multiple storeys, due to a loss of pressure through stairwells, and it may be necessary to change the test set up to remedy this.

The preferred method to achieve a uniform building pressure is to employ fan pressurisation systems at different locations within the building.

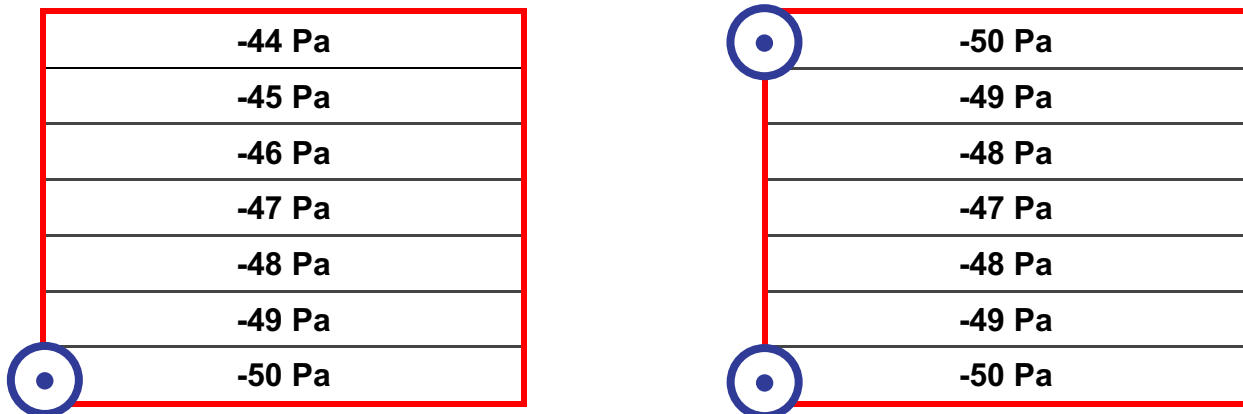

When it is not possible, due to the design of the building, to set up the equipment in different locations, then the following may be used to allow a greater flow of air to multiple storey:

1. Make use of light wells.
2. Make use of atria.
3. Make use of lift shafts providing suitable safety precautions are employed.
4. Make use of riser shafts if they have been sealed at the bottom floor and top floor roof level and not sealed horizontally at intermediate floors.

Where the guidance in this section cannot be implemented and the building has 10 or more storeys refer to [Section 3.8](#).

3.6 Permanently Compartmentalised Buildings

When there are no communal or circulation areas within the thermal envelope that connect to all areas of a building that is designed to be a single building, or these areas are outside of the thermal envelope, then all compartments are to be tested. This should be achieved through the co-pressurisation of the compartments, which is a process where similar building pressure differentials are recorded for the compartment subject to the test and adjoining compartments. The procedure of undertaking co-pressurisation is described in [Section 4](#).

The following methods are available for testing permanently compartmentalised buildings where all compartments in the building are not simultaneously tested. Method 1, where all compartments can be simultaneously tested is covered in companion reference document ATTMA TSL2.

When a compartment has multiple storeys further guidance on achieving a uniform building pressure across compartments with multiple storey can be found in [Section 3.5](#).

3.6.1 Method 2 – Co-pressure Testing Individual Compartments

Each compartment is tested individually and adjacent compartments, both horizontally and vertically, are co-pressurised to negate the air leakage between compartments. In this method, because the results for individual compartments are required, it is important that the building pressures are changed uniformly in all compartments so that the fans in one compartment do not overly influence the building pressures in adjoining compartments. This is the second most accurate method of testing a permanently compartmentalised building.

Optionally, to identify whether the adjoining compartments are improving the test result, with co-pressurisation, a method 3 test may also be undertaken on each compartment. If the method 3 test provides a better result than the method 2 test then the adjoining compartments were overly influencing the compartment being tested.

Test 1

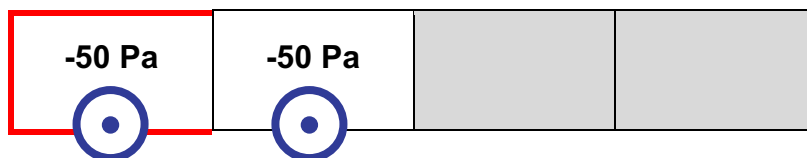

Test 2

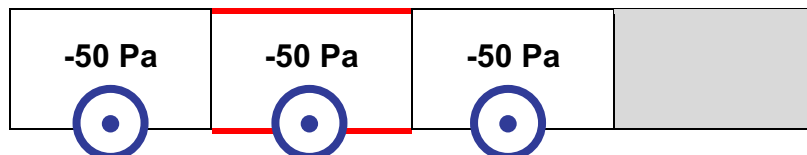

Test 3

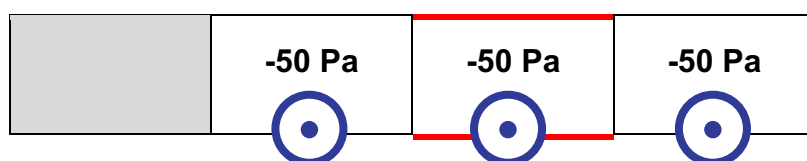

Test 4

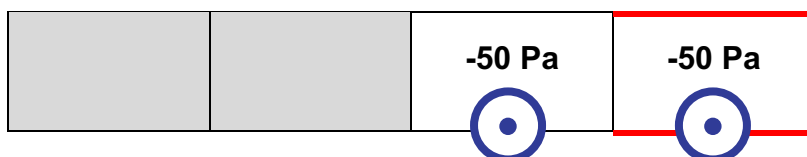

A result for the entire building is calculated from the individual tests as detailed in [Section 3.6.3](#).

3.6.2 Method 3 – Testing Each Compartment Individually

Each compartment is tested individually. This is the least accurate method of testing a permanently compartmentalised building as there is no negation of the air leakage between compartments and as such is likely to give a worse result than the other methods.

Test 1

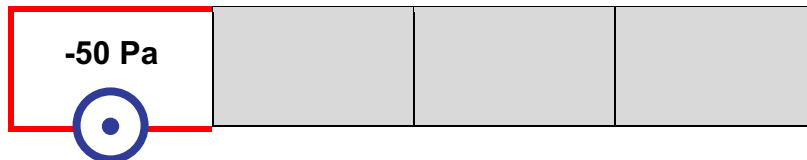

Test 2

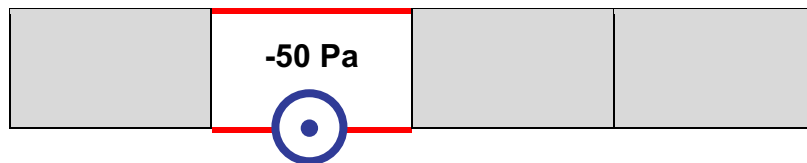

Test 3

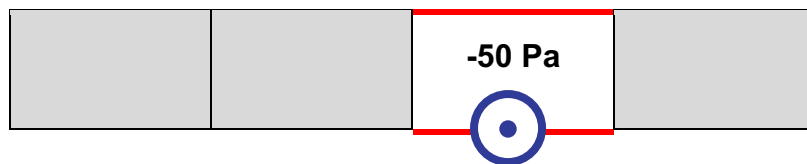

Test 4

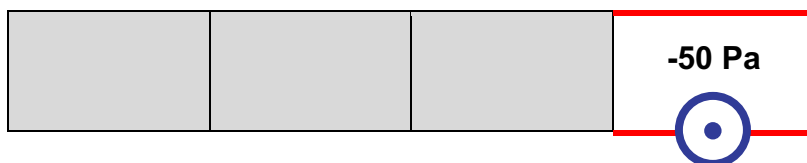

A result for the entire building is calculated from the individual tests as detailed in [Section 3.6.3](#).

3.6.3 Calculation of the Result

For method 1 the calculation of the result can be performed within the air tightness testing software as the whole building will have been tested as a single entity. For method 2 and 3 the result is calculated from the air leakage rates of the individual tests and the total envelope area of the building. The example below demonstrates the calculation process of the result for the entire building.

Example Result Calculation

1	2	3	4	5	6
----------	----------	----------	----------	----------	----------

Each of the 6 compartments have identical dimensions of 10 m x 5 m x 3 m and the width of the party wall between each compartment is 0.3 m. The calculation of the envelope areas is shown below:

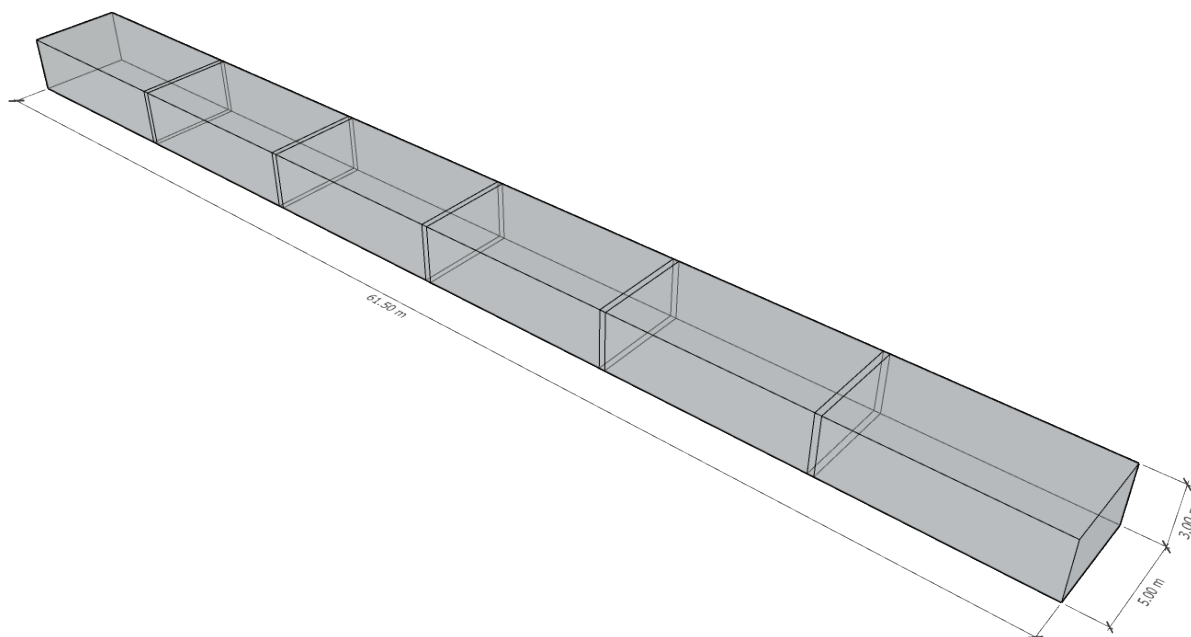

Full Building	
Floor Area	$= ((10 \times 6) + (0.3 \times 5)) \times 5 = (60 + 1.5) \times 5 = 61.5 \times 5 = 307.5 \text{ m}^2$
Perimeter	$= ((10 \times 6) + (0.3 \times 5) + 5) \times 2 = (60 + 1.5 + 5) \times 2 = 66.5 \times 2 = 133 \text{ m}$
Wall Area	$= 133 \times 3 = 399 \text{ m}^2$
Roof Area	$= ((10 \times 6) + (0.3 \times 5)) \times 5 = (60 + 1.5) \times 5 = 61.5 \times 5 = 307.5 \text{ m}^2$
Envelope Area	$= 307.5 + 399 + 307.5 = 1014 \text{ m}^2$

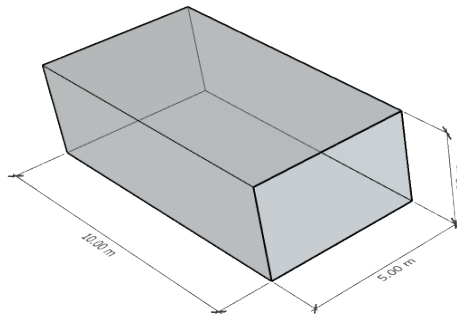

Compartments 1 and 6 – remove 1 party wall	
Floor Area	= $10 \times 5 = 50 \text{ m}^2$
Perimeter	= $10 + 5 + 10 = 25\text{m}$
Wall Area	= $25 \times 3 = 75 \text{ m}^2$
Roof Area	= $10 \times 5 = 50 \text{ m}^2$
Envelope Area	= $50 + 75 + 50 = 175 \text{ m}^2$

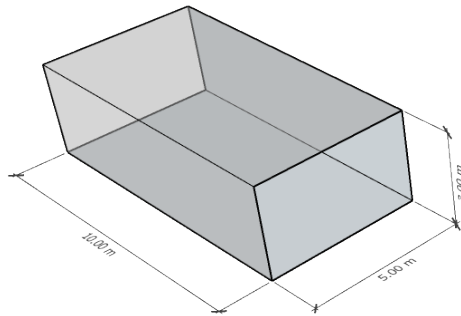

Compartments 2, 3, 4 and 5 – remove 2 party walls	
Floor Area	= $10 \times 5 = 50 \text{ m}^2$
Perimeter	= $10 + 10 = 20\text{m}$
Wall Area	= $20 \times 3 = 60 \text{ m}^2$
Roof Area	= $10 \times 5 = 50 \text{ m}^2$
Envelope Area	= $50 + 60 + 50 = 160 \text{ m}^2$

For the individual compartments the width of the party wall is excluded from the calculation as this removes the confusion about which compartment it should be applied to, however it is included in the full building envelope calculation which is used to calculate the result for the full building.

The air leakage at 50 Pa from each compartment test is then combined to give a total air leakage for the building and this is then divided by the building envelope area to give the result for the building. The full building envelope area is larger than the combined compartment envelope areas because the area of the party walls are included within the calculation.

Compartment	Air Leakage at 50 Pa (Q_{50})	Compartment Envelope Area (A_E)	Air Permeability (Q_{50} / A_E)
1	1,091 m ³ /h	175 m ²	6.23 m ³ .h ⁻¹ .m ⁻² @ 50 Pa
2	1,042 m ³ /h	160 m ²	6.51 m ³ .h ⁻¹ .m ⁻² @ 50 Pa
3	964 m ³ /h	160 m ²	6.03 m ³ .h ⁻¹ .m ⁻² @ 50 Pa
4	736 m ³ /h	160 m ²	4.60 m ³ .h ⁻¹ .m ⁻² @ 50 Pa
5	1,006 m ³ /h	160 m ²	6.29 m ³ .h ⁻¹ .m ⁻² @ 50 Pa
6	1,078 m ³ /h	175 m ²	6.16 m ³ .h ⁻¹ .m ⁻² @ 50 Pa
Total	5,917 m ³ /h	990 m ²	-

Full Building	Air Leakage at 50 Pa (Q_{50})	Envelope Area (A_E)	Air Permeability (Q_{50} / A_E)
Full Building	5,917 m ³ /h	1,014 m ²	5.84 m ³ .h ⁻¹ .m ⁻² @ 50 Pa

By using the compartment envelope area, rather than treating each compartment as a separate building, in terms of the envelope area, the results of each individual test are more representative of the result obtained for the full building. The results of individual compartment tests can therefore be used to target permanent sealing works to help ensure that the building achieves the desired result at the end of the process.

3.7 Phased Handover Buildings

Phased handover or occupancy of a building may preclude the testing of a whole building in practical terms. If such situations exist, then each phase of the building must be tested individually and from these the result for the whole building may be calculated. The combined areas of the phases must include all areas that would normally be included if the building was tested in its entirety.

Temporary screens may be constructed to isolate the phase subject to the test from adjoining phases of the building. It is important to consider that there may be leakage through these and the internal walls into the other areas of the building and it is therefore likely that the result for the building will be worse than if it was tested in its entirety.

If an adjoining phase is near completion, or has been completed, then co-pressurisation may be used instead of temporarily sealing. Information on co-pressurisation is detailed in [Section 3.6](#).

3.7.1 Calculation of the Result

The result for the whole building is calculated for the air leakage rates if the individual tests and the total envelope area of the building. The example below demonstrates the calculation process.

Example Result Calculation

The example development has three phases with a central core and two wings. The central core is to be completed first and then the wings will be added as separate phases afterwards. The phases are being constructed as separate fire compartments and the party walls, between the phases, have a width of 0.3m.

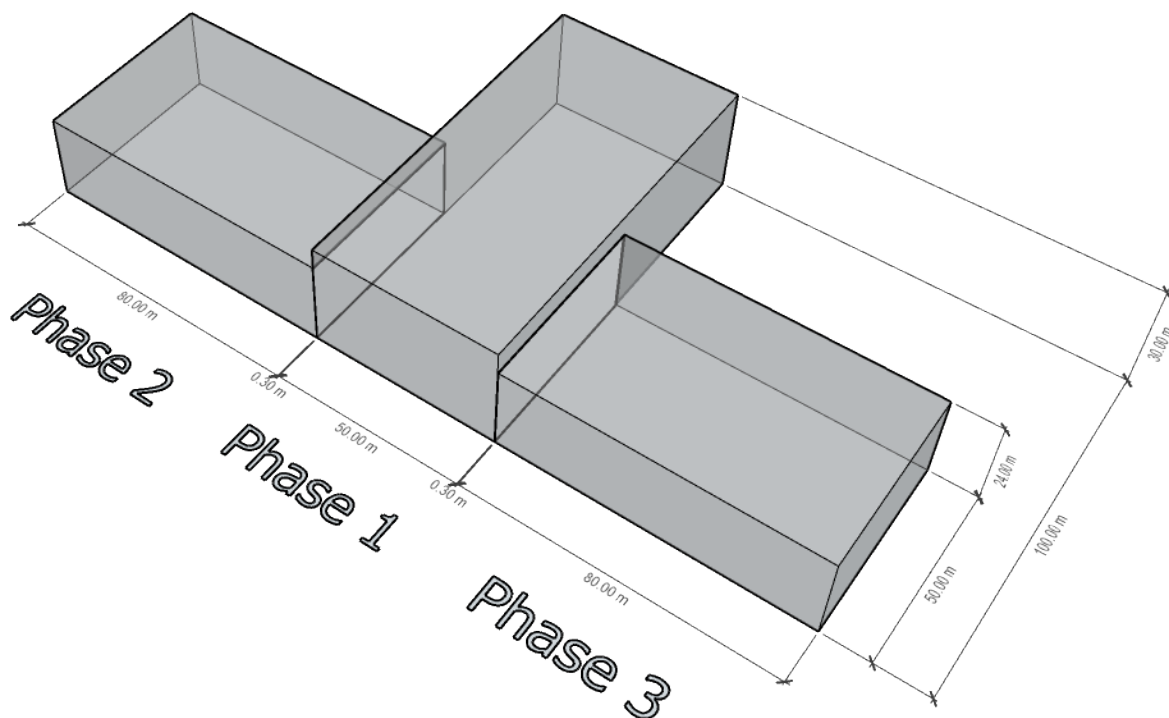

Full Building		
Floor Area		$= ((80 + 0.3 + 0.3 + 80) \times 50) + (50 \times 100) = (160.6 \times 50) + (50 \times 100)$ $= 8,030 + 5,000 = 13,030 \text{ m}^2$
Perimeter	All	$= (80 + 0.3 + 50 + 0.3 + 80 + 100) \times 2 = 310.6 \times 2 = 621.2 \text{ m}$
	Phase 1	$= (50 + 100) \times 2 = 150 \times 2 = 300 \text{ m}$
Wall Area		$= (621.2 \times 24) + (300 \times 6) = 14,908.8 + 1,800 = 16,708.8 \text{ m}^2$
Roof Area		$= ((80 + 0.3 + 0.3 + 80) \times 50) + (50 \times 100) = (160.6 \times 50) + (50 \times 100)$ $= 8,030 + 5,000 = 13,030 \text{ m}^2$
Envelope Area		$= 13,030 + 16,708.8 + 13,030 = 42,768.8 \text{ m}^2$

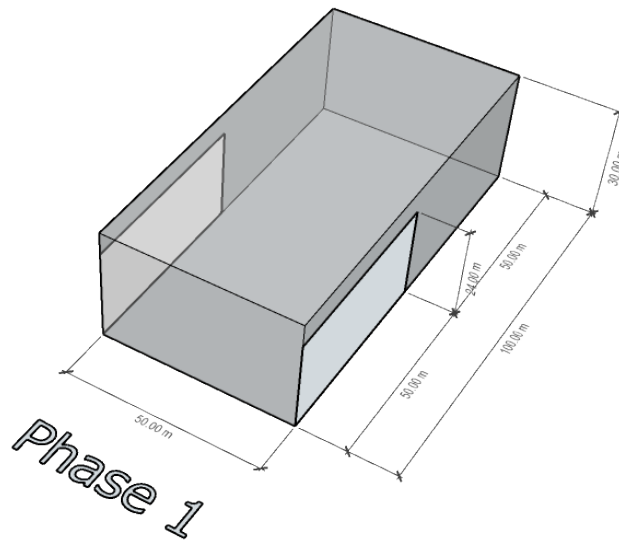

Phase 1	
Floor Area	= $50 \times 100 = 5,000 \text{ m}^2$
Perimeter	= $(50 + 100) \times 2 = 150 \times 2 = 300 \text{ m}$
Wall Area	= $(300 \times 30) - ((50 \times 24) \times 2) = 9,000 - (1,200 \times 2) = 9,000 - 2,400 = 6,600 \text{ m}^2$
Roof Area	= $50 \times 100 = 5,000 \text{ m}^2$
Envelope Area	= $5,000 + 6,600 + 5,000 = 16,600 \text{ m}^2$

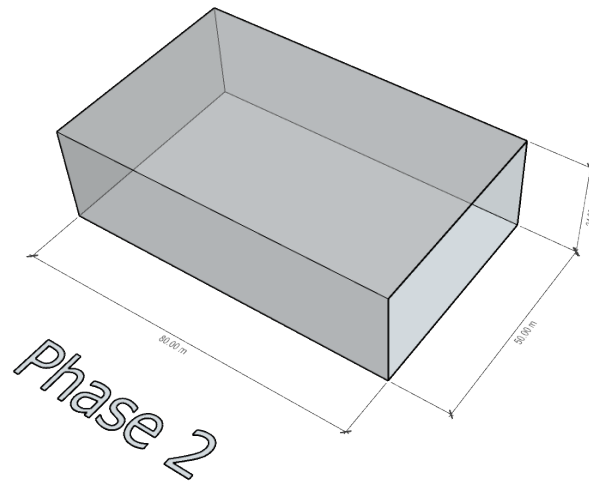

Phase 2	
Floor Area	= $80 \times 50 = 4,000 \text{ m}^2$
Perimeter	= $(80 + 50 + 80) = 210 \text{ m}$
Wall Area	= $210 \times 24 = 5,040 \text{ m}^2$
Roof Area	= $80 \times 50 = 4,000 \text{ m}^2$
Envelope Area	= $4,000 + 5,040 + 4,000 = 13,040 \text{ m}^2$

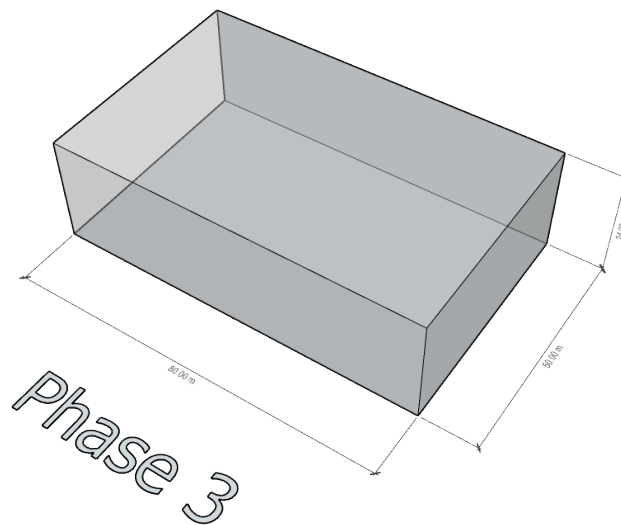

Phase 3	
Floor Area	= 80 x 50 = 4,000 m ²
Perimeter	= (80 + 50 + 80 = 210 m
Wall Area	= 210 x 2.4 = 5,040 m ²
Roof Area	= 80 x 50 = 4,000 m ²
Envelope Area	= 4,000 + 5,040 + 4,000 = 13,040 m²

The air leakage at 50 Pa from each phase test is then combined to give a total air leakage for the building and this is then divided by the building envelope area to give the result for the building. The full building envelope area is larger than the combined phase envelope areas because the area of the party walls are included within the calculation.

Phase	Air Leakage at 50 Pa (Q_{50})	Phase Envelope Area (A_E)	Air Permeability (Q_{50} / A_E)
1	84,992 m ³ /h	16,600 m ²	5.12 m ³ .h ⁻¹ .m ⁻² @ 50 Pa
2	61,158 m ³ /h	13,040 m ²	4.69 m ³ .h ⁻¹ .m ⁻² @ 50 Pa
3	64,548 m ³ /h	13,040 m ²	4.95 m ³ .h ⁻¹ .m ⁻² @ 50 Pa
Total	210,698 m³/h	42,680 m²	-

Full Building	Air Leakage at 50 Pa (Q_{50})	Envelope Area (A_E)	Air Permeability (Q_{50} / A_E)
Full Building	210,698 m ³ /h	42,768.8 m ²	4.93 m ³ .h ⁻¹ .m ⁻² @ 50 Pa

By using the phase envelope area, rather than treating each phase as a separate building, in terms of the envelope area, the results of each individual test are more representative of the result obtained for the full building. The results of individual phase tests can therefore be used to target permanent sealing works to help ensure that the building achieves the desired result at the end of the process.

3.8 High Rise Buildings

It can sometimes be difficult to achieve a uniform building pressure across buildings with multiple storeys, due to a loss of pressure through stairwells, and it may be necessary to change the test set up to remedy this. If a uniform building pressure can be achieved then the building must be tested in its entirety in accordance with ATTMA TSL2.

If the building has 10 or more storeys and a uniform building pressure cannot be achieved then the building may be defined as high-rise and tested using the guidance provided below.

3.8.1 Test Method

The methodology for testing high rise buildings is to test the building as zones. Zones are to be tested as a separate compartment and must have adjacent zones co-pressurised to reduce the air leakage between zones. The combined areas of the zones must include all areas that would normally be included if the building was tested in its entirety.

When determining the zones the following shall be considered:

1. Whether there are compartments already defined within the building which make for easier zoning of the whole building *i.e. fire breaks*.
2. The availability of set up locations for the air tightness testing equipment
3. Minimising the number of elements that span multiple storeys outside of the zones *i.e. service risers and lift shafts*.

It is preferable to set up fan pressurisation systems on the exterior of the building where possible but if this is not possible then the doorways into internal stairwells should be used. Typically with the fans set up on the exterior larger zones can be tested whereas when set up into internal stairwells typically only a single storey will be tested. The fan pressurisation systems used to co-pressurise should be set up in a different stairwell to the fan pressurisation system used to test the zone. It may be difficult to temporarily seal stairwells

Service risers may be temporarily sealed at the top and bottom of the zones, at the border within the service riser between the storeys that are being tested and those that are being co-pressurised, but only when permanent sealing works are not to be undertaken at these locations. The test shall be undertaken once the permanent sealing works are complete.

3.8.2 Calculation of the Results

The air permeability result for the building is calculated from the air leakage rates of the individual zones that have been tested. The air leakage rates for the individual zones tested are then combined to give an overall air leakage rate for the building. By dividing this by the full building envelope area the air permeability for the building can be calculated.

Example Result Calculation 1

An example building with a possible zoning regime is shown below. The basement to 5th floor are tested as a single zone with the 6th floor being co-pressurised. Followed by the 6th to 16th floor being tested as a single zone with the 5th floor being co-pressurised.

The 6th floor should allow some roof access above the 5th floor and as such may provide a set up location for equipment.

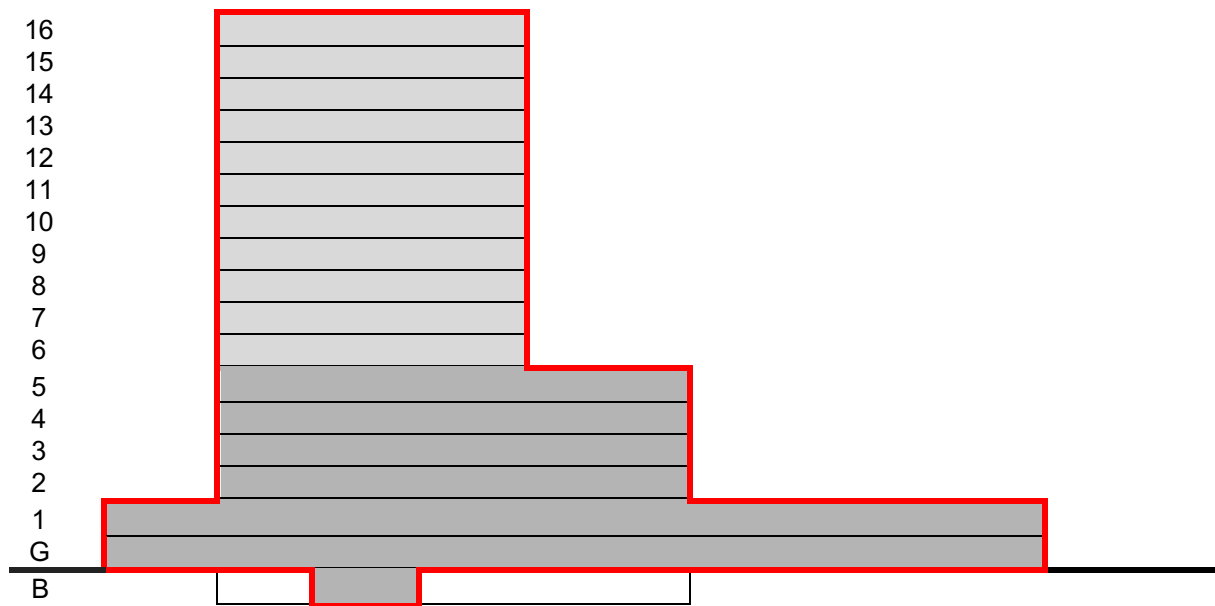

In the example each floor has a slab thickness of 0.3m. The calculation of the envelope areas is shown below:

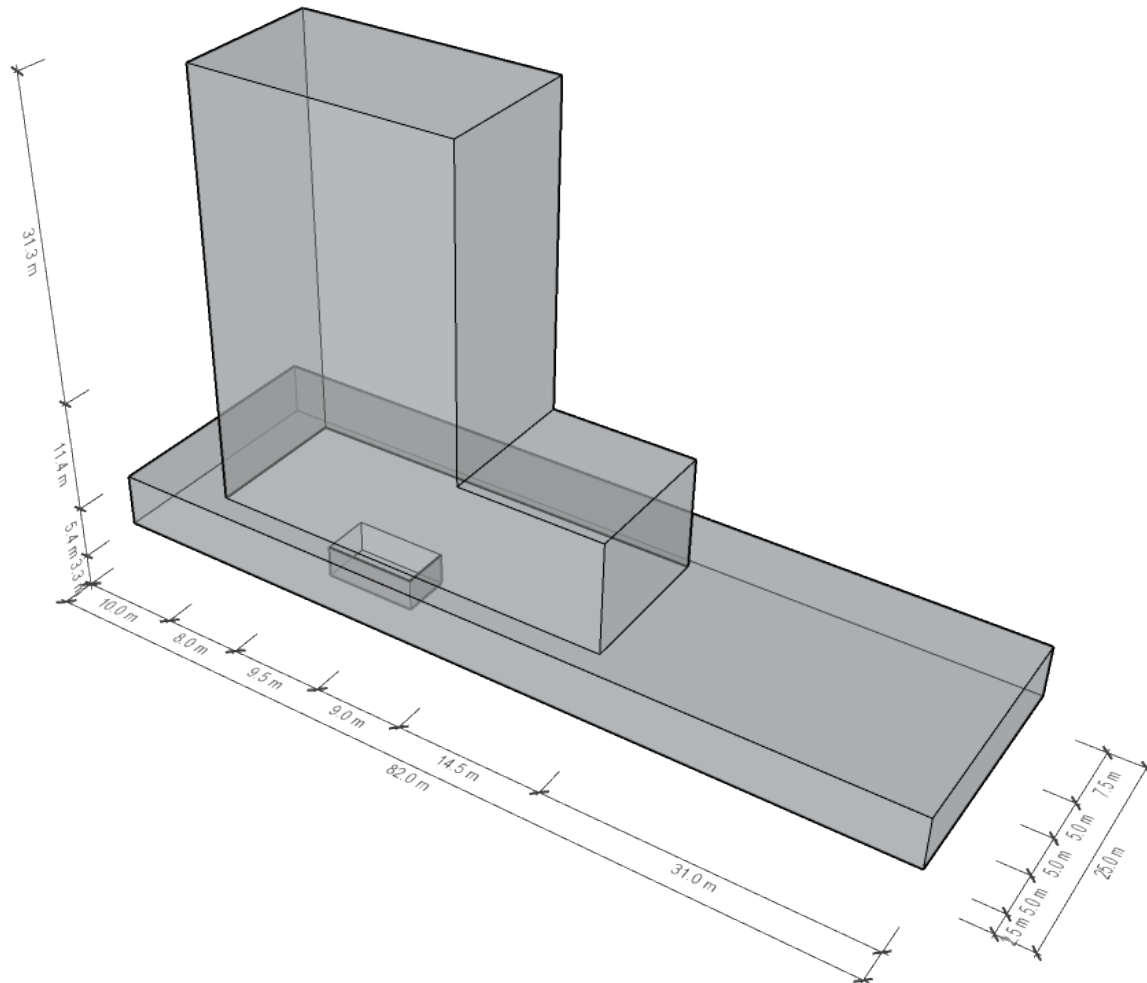

Full Building	
Floor Area	= 82 x 25 = 2,050 m ²
Perimeter	Basement = (9.5 + 5) x 2 = 14.5 x 2 = 29 m Ground & 1 = (82 + 25) x 2 = 107 x 2 = 214 m 2-5 = (41 + 15) x 2 = 56 x 2 = 112 m 6-16 = (26.5 + 15) x 2 = 41.5 x 2 = 83 m
Wall Area	Basement = 29 x 3.3 = 95.7 m ² Ground & 1 = 214 x 5.4 = 1,155.6 m ² 2-5 = 112 x 11.4 = 1,276.8 m ² 6-16 = 83 x 31.3 = 2,597.9 m ² Total = 95.7 + 1,155.6 + 1,276.8 + 2,597.9 = 5,126 m²
Roof Area	= 82 x 25 = 2,050 m ²
Envelope Area	= 2,050 + 5,126 + 2050 = 9,226 m²

Zone 1 - Basement to 5th floor

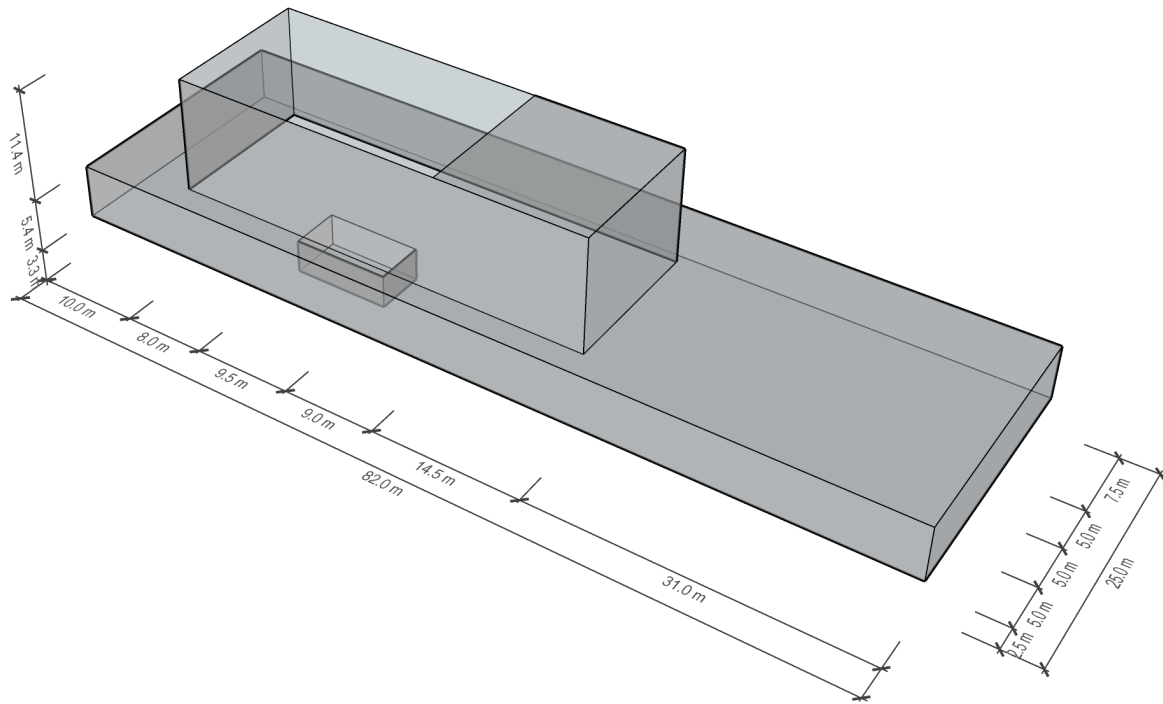

Zone 1	
Floor Area	= $82 \times 25 = 2,050 \text{ m}^2$
Perimeter	Basement = $(9.5 + 5) \times 2 = 14.5 \times 2 = 29 \text{ m}$ Ground & 1 = $(82 + 25) \times 2 = 107 \times 2 = 214 \text{ m}$ 2-5 = $(41 + 15) \times 2 = 56 \times 2 = 112 \text{ m}$
Wall Area	Basement = $29 \times 3.3 = 95.7 \text{ m}^2$ Ground & 1 = $214 \times 5.4 = 1,155.6 \text{ m}^2$ 2-5 = $112 \times 11.4 = 1,276.8 \text{ m}^2$ Total = $95.7 + 1,155.6 + 1,276.8 = 2,528.1 \text{ m}^2$
Roof Area	= $(82 \times 25) - (26.5 \times 15) = 2,050 - 397.5 = 1,652.5 \text{ m}^2$
Envelope Area	= $2,050 + 2,528.1 + 1,652.5 = 6,230.6 \text{ m}^2$

Zone 2 - 6th floor to 16th floor

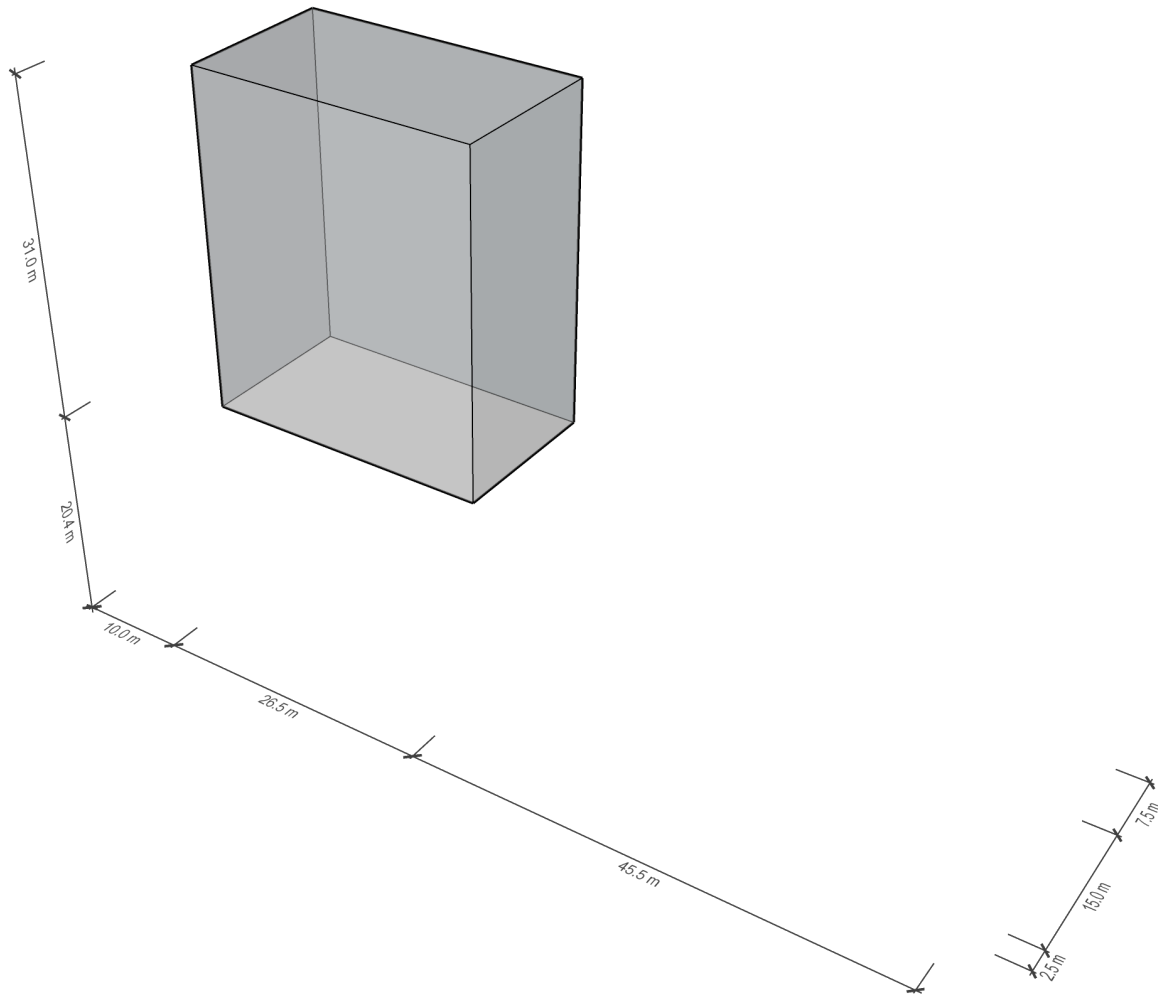

Zone 2	
Floor Area	= 0 m ²
Perimeter	= (26.5 + 15) x 2 = 41.5 x 2 = 83 m
Wall Area	= 83 x 31 = 2,573 m ²
Roof Area	= 26.5 x 15 = 397.5 m ²
Envelope Area	= 0 + 2,573 + 397.5 = 2,970.5 m²

The air leakage at 50 Pa from each zone test is then combined to give a total air leakage for the building and this is then divided by the building envelope area to give the result for the building. The full building envelope area is larger than the combined zone envelope areas because the area of the floor slab between the two zones are included within the calculation.

Zone	Air Leakage at 50 Pa (Q_{50})	Storey Envelope Area (A_E)	Air Permeability (Q_{50} / A_E)
Zone 1	28,934 m ³ /h	6,230.6 m ²	4.64 m ³ .h ⁻¹ .m ⁻² @ 50 Pa
Zone 2	13,942 m ³ /h	2,970.5 m ²	4.69 m ³ .h ⁻¹ .m ⁻² @ 50 Pa
Total	42,876 m ³ /h	9,201.1 m ²	4.66 m ³ .h ⁻¹ .m ⁻² @ 50 Pa

Full Building	Air Leakage at 50 Pa (Q_{50})	Envelope Area (A_E)	Air Permeability (Q_{50} / A_E)
Full Building	42,876 m ³ /h	9,226 m ²	4.65 m ³ .h ⁻¹ .m ⁻² @ 50 Pa

By using the zone envelope area, rather than treating each zone as a separate building in terms of the envelope area, the results of each individual test are more representative of the result obtained for the full building. The results of individual zone test can therefore be used to target permanent sealing works to help ensure that the building achieves the desired result at the end of the process.

Example Result Calculation 2

Another example of the previous building with a possible zoning regime is shown below. In this example each individual storey is tested as a zone.

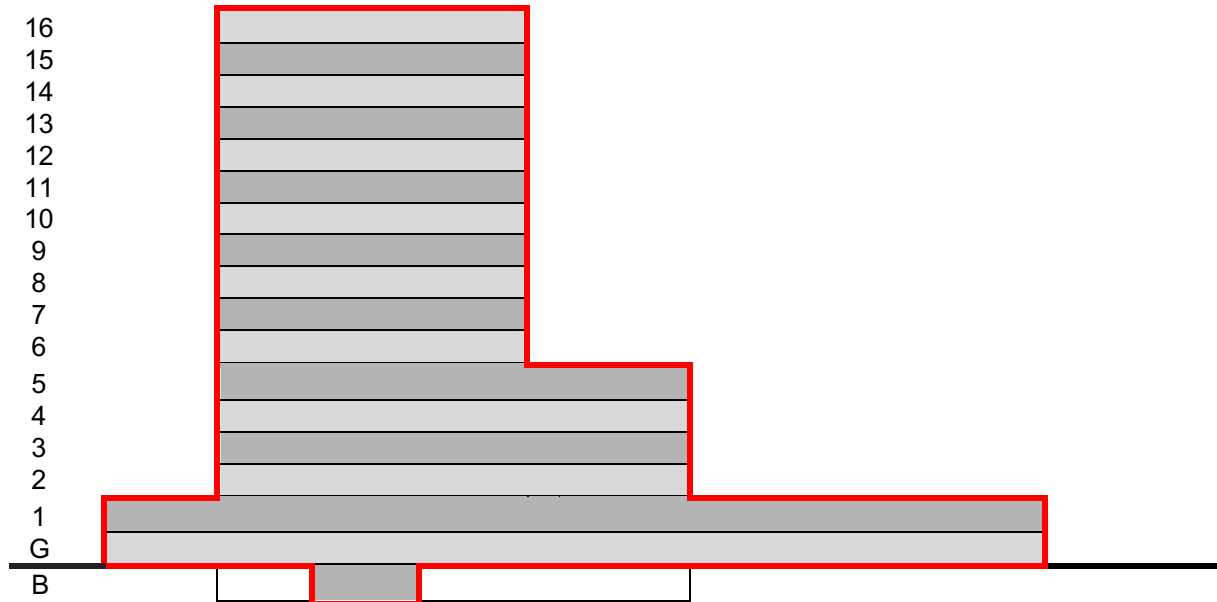

The calculation of the envelope areas for each storey is shown below:

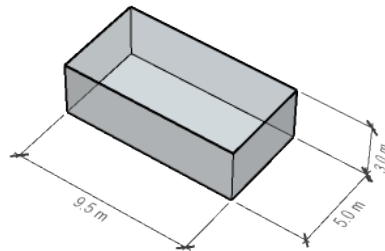

Basement	
Floor Area	= $9.5 \times 5 = 47.5 \text{ m}^2$
Wall Area	= $((9.5 + 5) \times 2) \times 3 = (14.5 \times 2) \times 3.3 = 29 \times 3 = 87 \text{ m}^2$
Roof Area	= 0 m^2
Envelope Area	= $47.5 + 87 + 0 = 134.5 \text{ m}^2$

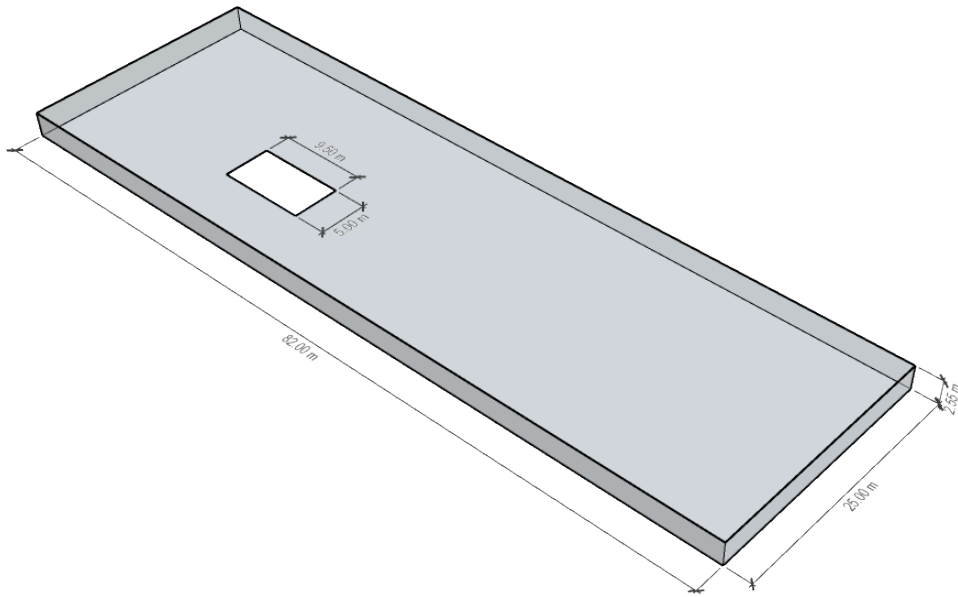

Ground Floor	
Floor Area	$= (82 \times 25) - (9.5 \times 5) = 2,050 - 47.5 = 2,002.5 \text{ m}^2$
Wall Area	$= ((82 + 25) \times 2) \times 2.55 = (107 \times 2) \times 2.55 = 214 \times 2.55 = 545.7 \text{ m}^2$
Roof Area	$= 0 \text{ m}^2$
Envelope Area	$= 2,002.5 + 545.7 + 0 = 2,548.2 \text{ m}^2$

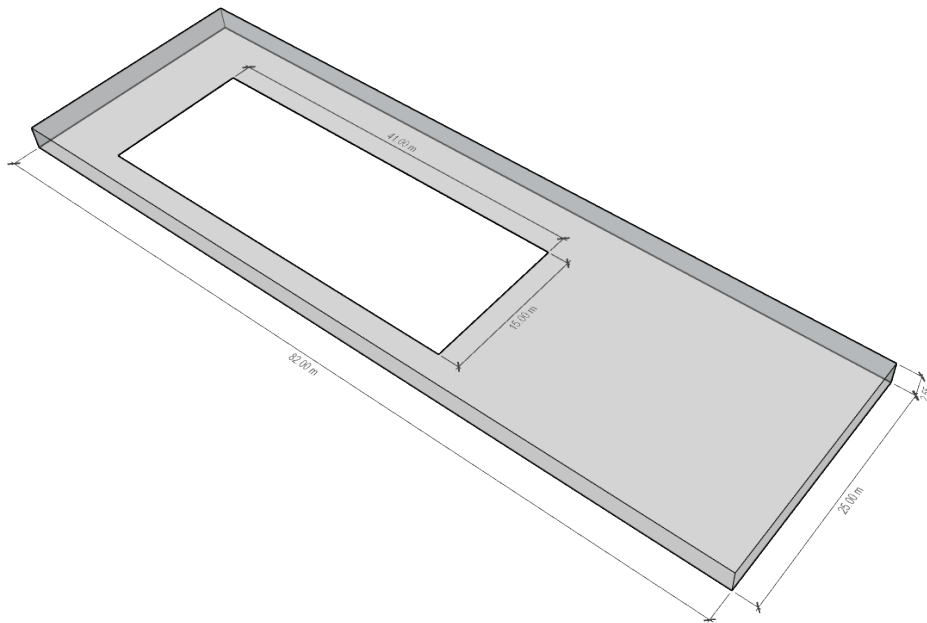

First Floor	
Floor Area	$= 0 \text{ m}^2$
Wall Area	$= ((82 + 25) \times 2) \times 2.55 = (107 \times 2) \times 2.55 = 214 \times 2.55 = 545.7 \text{ m}^2$
Roof Area	$= (82 \times 25) - (41 \times 15) = 2,050 - 615 = 1,435 \text{ m}^2$
Envelope Area	$= 0 + 545.7 + 1,435 = 1,980.7 \text{ m}^2$

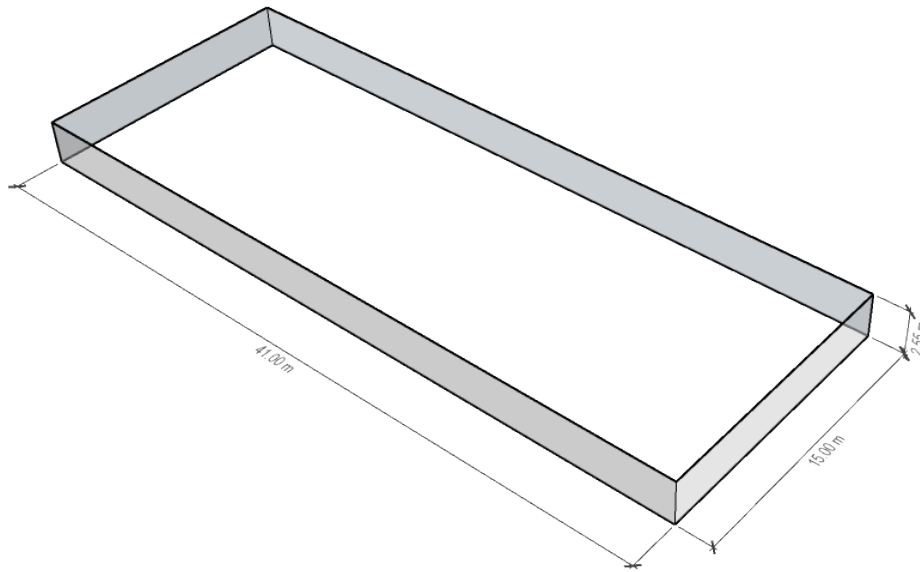

Second – Fourth Floor	
Floor Area	= 0 m ²
Wall Area	= ((41 + 15) x 2) x 2.55 = (56 x 2) x 2.55 = 112 x 2.55 = 285.6 m ²
Roof Area	= 0 m ²
Envelope Area	= 0 + 285.6 + 0 = 285.6 m ²

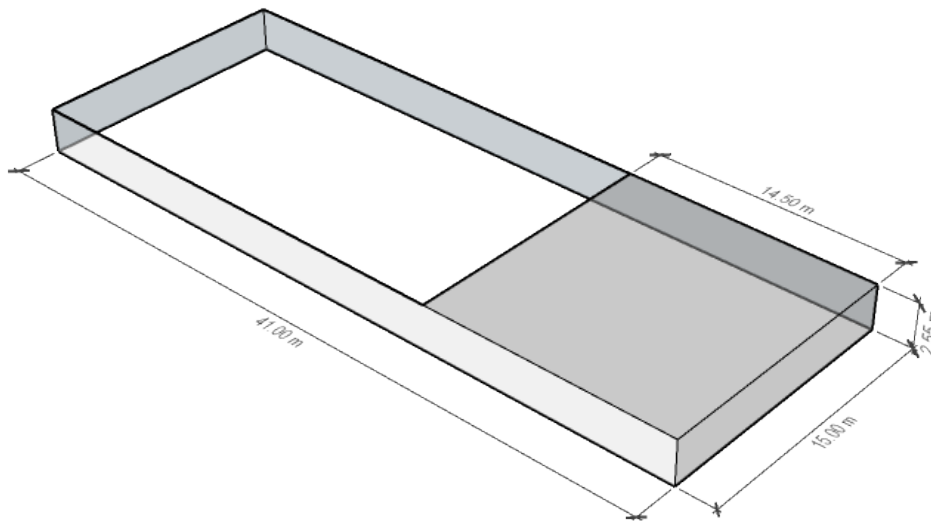

Fifth Floor	
Floor Area	= 0 m ²
Wall Area	= ((41 + 15) x 2) x 2.55 = (56 x 2) x 2.55 = 112 x 2.55 = 285.6 m ²
Roof Area	= 14.5 x 15 = 217.5 m ²
Envelope Area	= 0 + 285.6 + 217.5 = 503.1 m ²

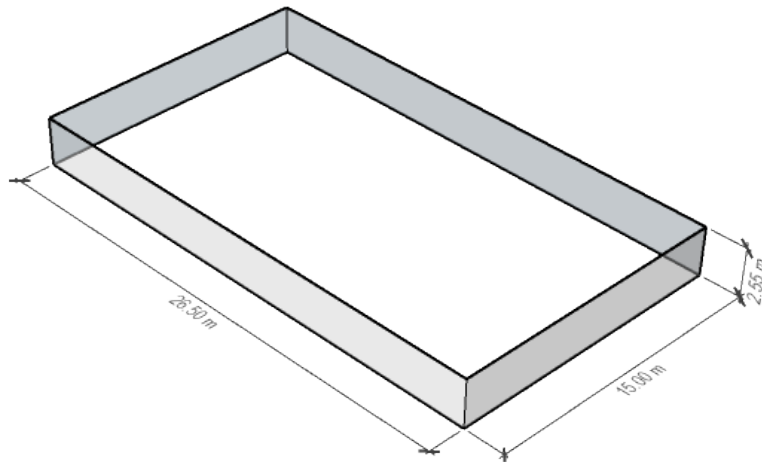

Sixth – Fifteenth Floor	
Floor Area	= 0 m ²
Wall Area	= ((26.5 + 15) x 2) x 2.55 = (41.5 x 2) x 2.55 = 83 x 2.55 = 211.7 m ²
Roof Area	= 0 m ²
Envelope Area	= 0 + 211.7 + 0 = 211.7 m ²

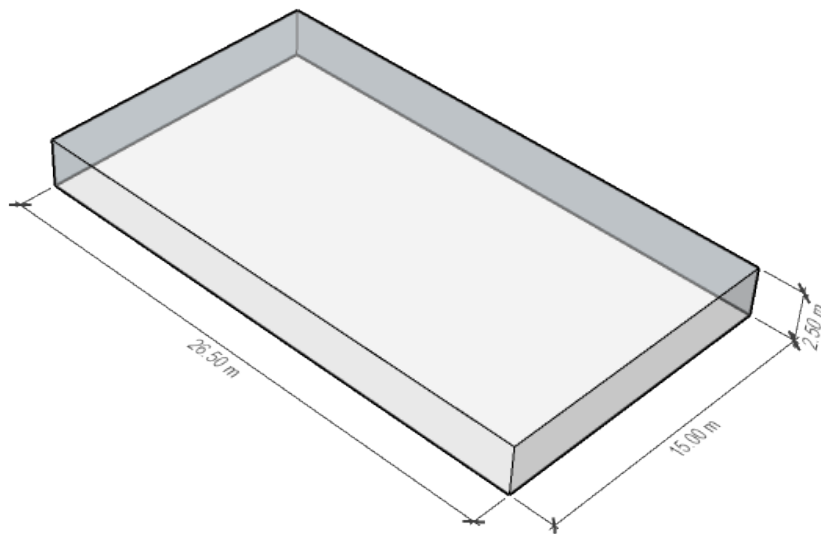

Sixteenth Floor	
Floor Area	= 0 m ²
Wall Area	= ((26.5 + 15) x 2) x 2.5 = (41.5 x 2) x 2.5 = 83 x 2.5 = 207.5m ²
Roof Area	= 26.5 x 15 = 397.5 m ²
Envelope Area	= 0 + 207.5 + 397.5 = 605 m ²

The air leakage at 50 Pa from each storey test is then combined to give a total air leakage for the building and this is then divided by the building envelope area to give the result for the building. The full building envelope area is larger than the combined storey envelope areas because the area of the floor slabs is included within the calculation.

Storey	Air Leakage at 50 Pa (Q_{50})	Storey Envelope Area (A_E)	Air Permeability (Q_{50} / A_E)
Basement	652 m ³ /h	134.5 m ²	4.85 m ³ .h ⁻¹ .m ⁻² @ 50 Pa
Ground	13,276 m ³ /h	2,548.2 m ²	5.21 m ³ .h ⁻¹ .m ⁻² @ 50 Pa
1	9,547 m ³ /h	1,980.7m ²	4.82 m ³ .h ⁻¹ .m ⁻² @ 50 Pa
2	1,051 m ³ /h	285.6 m ²	3.68 m ³ .h ⁻¹ .m ⁻² @ 50 Pa
3	1,437 m ³ /h	285.6 m ²	5.03 m ³ .h ⁻¹ .m ⁻² @ 50 Pa
4	1,498 m ³ /h	285.6 m ²	5.25 m ³ .h ⁻¹ .m ⁻² @ 50 Pa
5	2,445 m ³ /h	503.1 m ²	4.86 m ³ .h ⁻¹ .m ⁻² @ 50 Pa
6	978 m ³ /h	211.7m ²	4.62 m ³ .h ⁻¹ .m ⁻² @ 50 Pa
7	908 m ³ /h	211.7 m ²	4.29 m ³ .h ⁻¹ .m ⁻² @ 50 Pa
8	952 m ³ /h	211.7 m ²	4.50 m ³ .h ⁻¹ .m ⁻² @ 50 Pa
9	871 m ³ /h	211.7 m ²	4.12 m ³ .h ⁻¹ .m ⁻² @ 50 Pa
10	1,027 m ³ /h	211.7 m ²	4.85 m ³ .h ⁻¹ .m ⁻² @ 50 Pa
11	930 m ³ /h	211.7 m ²	4.40 m ³ .h ⁻¹ .m ⁻² @ 50 Pa
12	984 m ³ /h	211.7 m ²	4.65 m ³ .h ⁻¹ .m ⁻² @ 50 Pa
13	928 m ³ /h	211.7 m ²	4.39 m ³ .h ⁻¹ .m ⁻² @ 50 Pa
14	983 m ³ /h	211.7 m ²	4.65 m ³ .h ⁻¹ .m ⁻² @ 50 Pa
15	991 m ³ /h	211.7 m ²	4.68 m ³ .h ⁻¹ .m ⁻² @ 50 Pa
16	3,418 m ³ /h	605 m ²	5.65 m ³ .h ⁻¹ .m ⁻² @ 50 Pa
Total	42,876 m³/h	8,743.9 m²	4.90 m³.h⁻¹.m⁻² @ 50 Pa

Full Building	Air Leakage at 50 Pa (Q_{50})	Envelope Area (A_E)	Air Permeability (Q_{50} / A_E)
Full Building	42,876 m ³ /h	9,226 m ²	4.65 m ³ .h ⁻¹ .m ⁻² @ 50 Pa

By using the storey envelope area, rather than treating each storey as a separate building in terms of the envelope area, the results of each individual test are more representative of the result obtained for the full building. The results of individual storey tests can therefore be used to target permanent sealing works to help ensure that the building achieves the desired result at the end of the process.

3.9 Special Cases

There will no doubt be some, albeit few, buildings where none of the above approaches would be practicable and the following approach must be followed in order to demonstrate to the building control body, the main contractor and the client that their design requirements and the building specification have been met in the spirit of building regulations. The approach to 'Special Case' buildings can be split into three distinct stages which are:

1. Pre-construction of the building envelope
2. Construction of the building envelope
3. Post construction of the building envelope

3.9.1 Pre-Construction of the Building Envelope

This stage is before construction of the building envelope has commenced when the building has been designed and the main contractor appointed. At this stage the following steps must be followed:

- A document must be produced by the air tightness testing company that details why the building is a 'Special Case' and cannot be tested by any other approach. The document needs to include a thorough quality management procedure for air tightness issues, inspections of the building at regular intervals during construction, require robust QA site auditing procedures from main and package contractors, recommend full-scale mock-ups of complex and/or repeating sections of the building be tested and recommend air tightness testing of components.
- Air tightness testing companies that operate within a recognised Competent Person Scheme (CPS) must submit the document to their scheme for third party assessment and validation that the building is a 'Special Case' before the document may be sent to the main contractor.
- The main contractor submits the document to the building control body.
- It is desirable that the building control body approves this approach and confirms that the building is to be treated as a 'Special Case' based on the proposal submitted by the air testing company and the main contractor to avoid potential compliance issues at the end of the project.

A building classed as 'Special Case' at this stage cannot be used to demonstrate an air permeability of less than $4 \text{ m}^3 \cdot \text{h}^{-1} \cdot \text{m}^{-2} @ 50\text{Pa}$.

3.9.2 Construction of the Building Envelope

This stage is where construction of the building envelope has started. At this stage the following steps must be followed:

- For the purpose of certification, inspections must be carried out at least monthly during formation of the building envelope, and for more complex buildings this must increase appropriately.
- Key “stop points” should be agreed where certain details are to be inspected and signed off as acceptable before possibly being covered in. Photographic evidence of concealed details inspected shall be lodged with the main contractor and the air tightness testing company.
- Where there is a likelihood that air sealing details cannot be inspected progressively before such details become concealed, a system, such as photographic records, should be put in place so that there is comprehensive assurance that the building is built to the design criteria.
- Contractors’ tradesmen should be given demonstrations of what the goals are and what to be aware of in their work to avoid defects.
- Feedback from the results of mock-up or component testing should be implemented in the general design.

A building classed as ‘Special Case’ at this stage, rather than at pre-construction stage, cannot be used to demonstrate an air permeability of less than $5 \text{ m}^3 \cdot \text{h}^{-1} \cdot \text{m}^{-2} @ 50\text{Pa}$.

3.9.3 Post Construction of the Building Envelope

This stage is where the construction of the building envelope is complete or nearing completion to the point where buildings usually require an air tightness test. At this stage the following steps must be followed:

- Sample testing of some areas must be undertaken as part of this process. These tests must cover representative samples of the type of construction used and junctions between different types and to roof & floor.
- When testing of sample areas is carried out it is important to consider internal walls or temporary screens isolating test zones that will also be tested. Leakage through these elements will impact upon the result for the sample in question, although ultimately they may not form part of the building envelope.
- Sample testing must cover all types of elements and interfaces.
- All areas tested must pass the target for the building.
- An audit trail encompassing all site visit reports, sample test results, drawing reviews, the document produced by the air tightness testing company to indicate that the building is a ‘Special Case’ and sign off letter from the building control body should be kept and, at handover, be handed to the client for archiving and proof that the building has been signed off for airtightness by the air tightness testing company concerned.

A building classed as ‘Special Case’ at this stage, rather than pre-construction or construction stage, cannot be used to demonstrate an air permeability of less than the greater of the maximum allowed by the building regulations or building certification scheme. Where no maximum exists a value of $20 \text{ m}^3 \cdot \text{h}^{-1} \cdot \text{m}^{-2} @ 50\text{Pa}$ shall be used.

3.10 Building Preparation

Prior to the test being undertaken, the building must be prepared to allow effective pressurisation and depressurisation results to be obtained.

The client shall be advised and asked to ensure that all external doors and windows remain closed for the duration of the test.

Heating and ventilation systems are to be switched off from source before the test is conducted.

3.10.1 Test Methods

The methods of building preparation are identified in BS EN ISO 9972:2015, as:

- Method 1. Building in use, natural ventilation openings are closed and whole building ventilation systems or air conditioning systems are sealed.
- Method 2. Building envelope, all intentional ventilation openings are sealed.
- Method 3. A test for a specific purpose, the treatment of intentional opens is adapted for compliance with an air tightness specification.

The method of building preparation is often dependent upon national requirements and this will need to be confirmed by the testing organisation prior to the commencement of testing. *i.e. In England the approved method of building preparation is Method 2.*

3.10.2 Temporary Sealing

Table 4 and 5 highlight how the openings within a building are to be prepared for a test for Methods 1 and 2. For Method 3 guidance regarding building preparation should be sought from the organisation which has provide the air tightness specification.

Table 4 – Method 1 Openings in the Building

Opening	Status
Ventilation opening for natural ventilation	Closed
Openings for whole building mechanical ventilation or air conditioning (continual use)	Temporarily Sealed
Openings for mechanical ventilation or air conditioning (intermittent use)	Closed
Windows, doors, trapdoors, loft hatches and access hatches in the envelope	Closed
Openings not intended for ventilation	Closed

Table 5 – Method 2 Openings in the Building

Opening	Status
Ventilation opening for natural ventilation	Temporarily Sealed
Openings for whole building mechanical ventilation or air conditioning (continual use)	Temporarily Sealed
Openings for mechanical ventilation or air conditioning (intermittent use)	Temporarily Sealed
Windows, doors, trapdoors, loft hatches and access hatches in the envelope	Closed
Openings not intended for ventilation	Closed

Where an opening must be closed but closure is not possible the opening shall be left as found and not temporarily sealed.

It is the responsibility of the tester to ensure that the temporary seals are in accordance with the relevant building preparation method before commencement of a test.

Temporary seals may be applied internally or externally, but not both. Temporary seals must only be applied to the ventilation terminals or grilles and not the adjacent walls or ceilings.

Passive ventilation systems in unconditioned spaces, such as louvres to plant rooms on external walls, shall not be temporarily sealed.

Temporary seals employed during the test, including the method of closure, must be checked and recorded for inclusion in the test report.

When sheltered housing contains a mix of residential units and common areas the doors to the residential units may be temporarily sealed when testing the common areas.

When a zone in a phased handover building is tested the entirety of the area adjoining the other zones may be temporarily sealed. This may not be practicable and typically the doorways between the existing build and the extension are only sealed.

3.10.3 Temporary Sealing - Deviations

Temporarily sealing items is not a method of compliance and usually occurs when the condition of the building does not match that outlined in [Appendix F](#). Temporary sealing items not listed in [point 2](#) may result in the report being rejected by the Competent Person's Scheme and/or building control.

Temporarily sealing a broken or missing component can only be carried out as an exception and only where it is not possible to fix or install a single broken or missing component and never 'gaps and cracks'. For a broken or missing component to be classed as an exception then it must not be present on more than one plot on the date of test. Table 5 details when the temporarily sealing of a missing or broken component is acceptable.

When a building is a shell and core development, where the developer's scope of works is the construction of the base building only, it is acceptable to temporarily seal missing components that are not within the scope of works. Any missing component temporarily sealed must be declared as a deviation as normal and the test report and test certificate must indicate that this is a shell and core development.

Table 5 – Acceptability of deviations

Component	Acceptable or unacceptable
Ventilation systems	<p>It is acceptable to temporarily seal the opening when ventilation systems have not been installed if the ductwork has been installed in the wall or ceiling and there is a permanent seal around the ductwork.</p> <p>It is never acceptable to temporarily seal the opening when ventilation systems have not been installed if the ductwork has not been installed.</p>
Combustion appliances	<p>It is acceptable to temporarily seal the flue opening when a combustion appliance has not been installed if the ductwork has been installed in the wall or ceiling and there is a permanent seal around the ductwork.</p> <p>It is never acceptable to temporarily seal the flue opening when a combustion appliance has not been installed if the ductwork has not been installed.</p>
Access	<p>It is acceptable to temporarily seal a hole created for access if it is to be patch plastered or tiled and grouted.</p> <p>It is never acceptable to temporarily seal access panels with an openable door or openings where they are to be installed.</p>
Sanitaryware	<p>It is acceptable to temporarily seal the end of supply and waste pipes when sanitaryware is not installed.</p> <p>It is never acceptable if the supply and waste pipes have not been installed or the pipes are additionally temporarily sealed at the floor, wall or ceiling.</p>
Windows, doors, trapdoors and loft hatches	<p>It is acceptable to replace missing glazing with another material such as board providing this is not temporarily sealed to the frame.</p> <p>It is never acceptable to temporarily seal a window, door, trapdoor or loft hatch where elements of the component have not yet been installed or where it does not close correctly.</p> <p>It is never acceptable to temporarily seal lift, service riser and plant room doors.</p>
Electrical sockets, lighting and controls	<p>It is never acceptable to temporarily seal missing electrical sockets, lighting or controls.</p>
Bath panels and shower trays	<p>It is never acceptable to temporarily seal a bath panel or shower tray or where they are yet to be installed.</p>
Boxing and vanity units	<p>It is never acceptable to temporarily seal any area of boxing or vanity units.</p>
Smoke vents	<p>It is never acceptable to temporarily seal any area of smoke vents.</p>
Protective covers, layers or screens on building elements	<p>It is acceptable for protective covers, layers or screens to remain in place on a building element when it will not artificially improve the test result.</p> <p>It is never acceptable for a protective cover, layer or screen to remain in place on a building element during a test when it may artificially improve the test result.</p>

Section 4 – Site Test Procedure

4.1 Test Direction

Either a pressurisation, depressurisation or testing in both directions must be undertaken. If testing in both directions the result is the average of both tests.

4.2 Test Procedure Detail

The procedure for undertaking a test is included within this section and detail on the technical validity of a test can be found in [Appendix B](#).

4.2.1 Installation of Test Equipment

The fan pressurisation system may hinder the exit point(s) from the building. Whilst it is safe for the test to be undertaken with people remaining inside the building, it is often easier for the site operatives/staff to vacate the building for the period of the test.

The fan pressurisation system must be set up in a location that will not hinder airflow from or to the fan. For example, it is often required to set the fan pressurisation system up at the rear of a building to avoid the air flow being directed against a wall. The preferred set up location is in a window as this represents a smaller area in the envelope of the building.

There shall also be an adequate air supply to the fan pressurisation system, for example if the equipment is located within a door to a garage, the external garage door shall be open.

It is acceptable to temporarily seal around the fan pressurisation system should the window or door frame hinder a reasonable seal being achieved.

4.2.2 Approved Software

It is mandatory that the latest version of the approved software is used to achieve the correct result. Software can either be proprietary software, typically from equipment manufacturers, or a spreadsheet type software which has been created by the testing company.

All software shall be verified against [Appendix E](#) to ensure compliance.

Coefficients and exponents from the latest fan calibration relative to the date of the test must be used.

4.2.3 Internal Pressure Tube

The indoor pressure is measured at the approximate geometric centre of the building or part thereof being tested. Measurements are obtained through small bore tubing (no greater than 6mm internal diameter). The internal pressure tube must be located away from corridors or doorways where air movement (dynamic pressure) is likely to affect the readings obtained.

Pressure tubes shall be kept away from locations where they may be trapped or may become heated or cooled excessively.

For buildings that are greater than 6 storeys, or 18 metres in height and 3 or more storeys, a second internal pressure tube shall be run to the centre of the highest floor level and a third internal pressure tube to the centre of the lowest floor level.

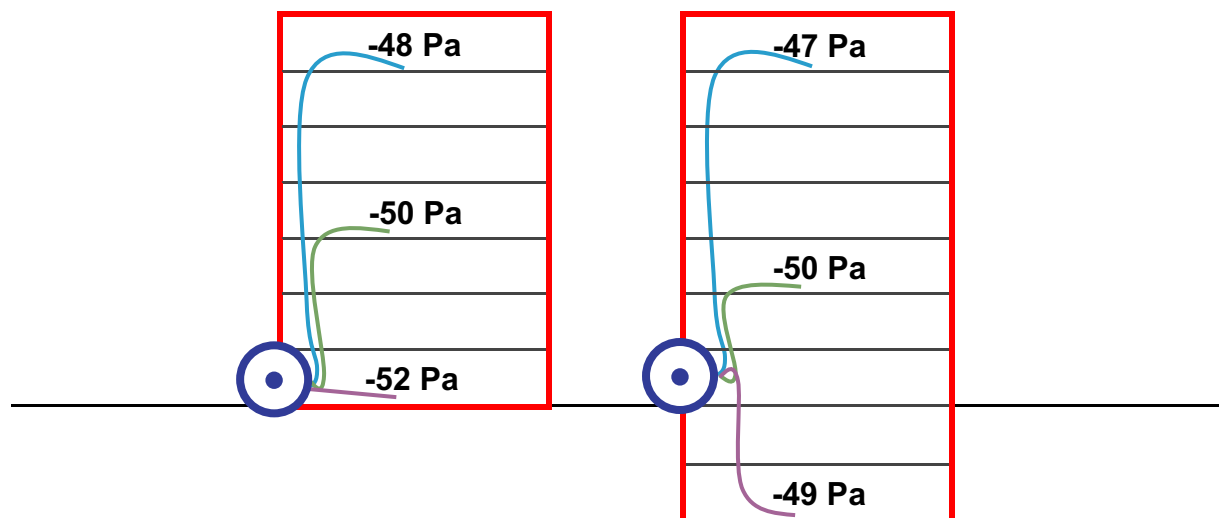

4.2.4 External Pressure Tube

The external pressure tube should be located away from the building envelope. This must terminate out of the air flows induced by the fan pressurisation system and sheltered from any wind. Where this is not possible, such as when testing a storey in a high-rise building, the reference tube should be taken to an adjacent area or floor, and all the doors and windows opened to ensure a free air supply is provided. If this is not possible then the reference tube should be taken to the closest location where it can be positioned externally.

The tube termination should be pointed downwards to avoid rain and moisture obstructing the tube. Pressure tubes should be kept away from locations where they may be trapped or may become heated or cooled excessively.

4.2.5 'Pre-Test' External Temperature Shall be Measured and Recorded

External temperature shall be measured and recorded (T_{e1}). The temperature is taken from the location the air is drawn for the fan. Temperature shall be taken to the closest single decimal place, e.g. 12.2°C.

External temperature shall not be taken in direct sunlight.

4.2.6 'Pre-Test' Internal Temperature Shall be Measured and Recorded

Internal temperature (T_{i1}) shall be measured and recorded. Temperature shall be taken to the closest single decimal place, e.g. 12.2°C. For dwellings up to and including 3 storeys tall or for non-dwellings up to and including 6 storeys tall, this may be a single measurement in the approximate geometrical centre of the building.

For buildings that are greater than 6 storeys measurements shall be taken once for every 6 storeys or part thereof, and averaged e.g. *in a 7 storey building, 2 measurements shall be taken.*

4.2.7 'Pre-Test' Barometric Pressure Shall be Measured and Recorded

Barometric pressure is measured and recorded on the bottom storey of the building subject to the test. The barometric pressure shall be recorded to zero decimal place in Pa or to the closest single decimal place in hPa, e.g. 101325 Pa or 1013.3 hPa.

4.2.8 'Pre-Test' Zero Flow Pressure Differences are Measured

All pressure and flow measurement devices should be zeroed as necessary at this stage.

With the opening(s) of the fan pressurisation system temporarily covered, the pressure measuring devices should be connected to the internal and external pressure tubes. Record the zero-flow pressure differences to 1 decimal place in Pascal, e.g. 1.0 Pa. The following average zero flow pressure differences shall be calculated:

$\Delta P_{0,1+}$	<i>The average of positive values recorded</i>
$\Delta P_{0,1-}$	<i>The average of negative values recorded</i>
$\Delta P_{0,1}$	<i>The average of all values recorded</i>

Any values of 0 Pa are only to be included in the average of all values $\Delta P_{0,1}$.

Wind speed and temperature may be the cause of excessive zero flow pressure differences and waiting until the environmental conditions change may reduce the figure to an acceptable level as stated in [Appendix B](#). It should also be confirmed that mechanical ventilation systems are suitably isolated so as not to cause this effect.

4.2.9 Fan on Test

Once acceptable zero flow pressure difference readings have been taken, covers from the fan pressurisation system should be removed. Fan pressurisation systems can then be turned on to pressurise or depressurise the building.

The fan shall be turned on and a building pressure differential applied with readings typically taken in the range of ± 10 to ± 90 Pa. It is recommended that fan pressurisation systems are switched on in a controlled manner. Great care must be taken to ensure that the building does not become over pressurised as this may present a risk to internal finishes, the fabric of the building and temporary seals applied.

4.2.10 Uniform Building Pressure Check

When additional internal pressure tubes are used a single building pressure differential must be recorded from each location. These shall be recorded simultaneously at a building pressure differential of 50Pa in the geometric centre of the building or at the highest building pressure achieved below this. This shall be used to ascertain that a uniform building pressure differential is achieved. See [Section 4.2 Part 3](#) for details when this must be done.

4.2.11 Fan Readings and Building Pressure Differentials are Measured

The test is carried out by taking a series of measurements of air flow rates and corresponding building pressure differentials over a range of fan flows.

Adequate time must be allowed for induced pressures to stabilise throughout the building for each measurement. Larger buildings, or buildings subject to a high wind load may take longer to settle, whereas a smaller building will settle very quickly. Buildings with an air permeability below $1 \text{ m}^{-3} \cdot \text{h}^{-1} \cdot \text{m}^{-2}$ @ 50Pa may take a long time (>60s) to stabilise.

Measurements shall be stable for 30 seconds before the reading is taken. Building pressure differentials shall be recorded to 1 decimal place in Pascal *e.g. 1.0 Pa*.

If fan flows are calculated from fan flow pressure then they shall be recorded to 1 decimal place in Pascal *e.g. 1.0 Pa*.

Testers that use automatic software may need to amend their settings to take measurements over an increased period. Manufacturers' instructions shall be followed if required.

Once steady pressure and flow readings are obtained, these shall be recorded. Where multiple fans are utilised, it must be ensured that flow measurement readings are taken for each fan.

Where possible measurements should be recorded over a range of at least 30 Pa between the lowest and highest building pressure differential.

During the test it should be confirmed and recorded that the building conditions have remained stable during the test, and that temporary seals and external doors, windows, and vents have remained closed.

4.2.12 The Fan is Switched Off and Covered

When a full set of data has been recorded, the fan pressurisation system should be switched off and the fan opening re-covered. A period of 60 seconds shall be allowed before point 13 commences.

4.2.13 'Post-Test' Zero Flow Pressure Differences are Measured

Record the zero-flow pressure differences to 1 decimal place in Pascal, e.g. 1.0 Pa. The following average zero flow pressure differences shall be calculated:

$\Delta P_{0,2+}$	<i>The average of positive values</i>
$\Delta P_{0,2-}$	<i>The average of negative values</i>
$\Delta P_{0,2}$	<i>The average of all values</i>

Any values of 0 Pa are only to be included in the average of all values $\Delta P_{0,2}$.

4.2.14 'Post-Test' Internal Temperature Shall be Measured and Recorded

Internal temperature (T_{i2}) shall be measured and recorded. See advice in [Section 4.2 Part 6](#). Temperature shall be taken to the closest single decimal place, e.g. 12.2°C.

4.2.15 'Post-Test' External Temperature Shall be Measured and Recorded

External temperature shall be measured and recorded (T_{e2}). Temperature shall be taken to the closest single decimal place, e.g. 12.2°C.

4.2.16 'Post-Test' Barometric Pressure Shall be Measured and Recorded

Barometric pressure is measured and recorded on the bottom storey of the building subject to the test. The barometric pressure shall be recorded to zero decimal place in Pa or to the closest single decimal place in hPa, e.g. 101325Pa or 1013.3 hPa.

4.3 Test Results

The recorded test data must be analysed and corrected in accordance with the standard equations contained within [Appendix A](#) and checked that it is technically valid in accordance with [Appendix B](#).

For this standard the final air tightness test result is expressed as air permeability which is a rate of leakage per hour per square metre of building envelope at a reference pressure differential of 50 Pa ($\text{m}^3 \cdot \text{h}^{-1} \cdot \text{m}^{-2}$ @ 50 Pa). This is calculated by dividing the total calculated leakage flow rate (Q_{50}) by the envelope area (A_E).

Section 5 - Test Report

5.1 Companies Operating Within a Competent Person Scheme

Companies that operate within a recognised Competent Person Scheme (CPS) may demonstrate competence by using a Lodgement certificate supplied by using their Competent Person Scheme Lodgement System as evidence of a test having been conducted.

Whilst Lodgement certificates are not full test reports, they provide a sufficient amount of information required for the assessor or Building Control to decide about the validity of the test.

5.1.1 Lodgement Certificate Contents

Lodgement certificates shall contain as a minimum:

- a) Plot number
- b) Site address
- c) Tester name
- d) Tester unique identifier / registration number
- e) Testing company name
- f) Level of competence within the CPS scheme
- g) Temporary sealing applied
- h) Deviations
- i) Contact details of CPS, including address, contact number and email address
- j) Unique certificate reference number (UCRN)
- k) Building volume
- l) Building envelope area
- m) Date of test
- n) Test standard
- o) Air Permeability results to 2 decimal places
- p) Flow Exponent (n) to 2 decimal places
- q) Coefficient of Determination (r^2) to 3 decimal places

A full, compliant report in accordance with [Section 5.2](#) may be sought by any industry stakeholder (Client, Building Control, Energy Assessor, etc.) and must be created if a request for the full report is made, subject to confidentiality clauses as necessary.

5.2 Companies which do not Operate within a Competent Person Scheme

For companies which do not operate within a Competent Person Scheme, the report shall contain at least the following information:

- a) All details necessary which identify the building tested, postal address and estimated date of construction of the building.
- b) A reference to this standard and any deviation from it.
- c) Test object:
 - Description of which parts of the building were subject to the test;
 - Envelope area and volume;
 - Documentation of test calculations so that the stated results can be verified;
 - The general status of openings on the building envelope, latched, sealed, open, etc.;
 - Detailed description of temporarily sealed openings, if any;
 - The type of heating, ventilating and air conditioning system.
- d) Apparatus and procedure:
 - Equipment and technique employed;
 - Serial number for each calibrated item of equipment used;
 - Date of calibration expiry for each calibrated item of equipment used.
- e) Test data:
 - Zero-flow pressure differences $\Delta P_{0,1+}$, $\Delta P_{0,1-}$, $\Delta P_{0,2+}$, $\Delta P_{0,2-}$, $\Delta P_{0,1}$ and $\Delta P_{0,2}$
 - Displayed to 1 decimal place
 - Internal and external temperatures before and after the test
 - Displayed to 1 decimal place
 - Barometric pressure before and after the test
 - Displayed to 0 decimal place in Pa, 1 decimal place in hPa.
 - Table of building pressure differentials and measured and corrected air flow rates
 - To 1 decimal place
 - Air leakage graph, with value of the coefficient of determination r^2
 - To 3 decimal places
 - The air flow exponent, n ,
 - To 2 decimal places
 - The air flow coefficient C_{env} ,
 - To 3 decimal places
 - The air leakage coefficient C_L ,
 - To 3 decimal places
 - Air permeability result
 - To 2 decimal places
- f) Date and time of test.
- g) Name and address of organisation/individual carrying out the test and details.

Appendices

Appendix A – Equations and Corrections

Appendix B – Technical Validity

Appendix C – Test Equipment and Calibration Requirements

Appendix D – Equivalent Leakage Area (ELA)

Appendix E – Software Verification Process

Appendix F – Checklists

Appendix A - Equations and Corrections

A.1.0 Equations

A.1.1 Corrections for zero flow pressure differences

Zero flow pressure difference corrections should be applied to the observed building pressure differentials for wind and stack effects. Subtract the average zero flow pressure difference from each of the measured building pressure differentials, Δp_m , to obtain the induced building pressure differentials, Δp_{env} , using equation 1: (The plus or minus signs should be included when undertaking this calculation)

$$\Delta p_{env} = \Delta p_m - \frac{\Delta p_{0,1} + \Delta p_{0,2}}{2} \quad 1$$

Where $\Delta p_{0,1}$ is the average of all zero flow pressure differences at the start of the test and $\Delta p_{0,2}$ is the average of all zero flow pressure differences at the end of the test.

A.1.2 Calculation of air density

The air density, ρ , in kg.m^{-3} , at a temperature, θ , in $^{\circ}\text{C}$ and at the absolute pressure, p_{bar} , in Pa, can be obtained by equation 2. This may be calculated as an average of temperature and absolute pressure readings taken immediately before and immediately after the test.

$$\rho = \frac{p_{bar} - 0.37802 \cdot p_v}{287.055 \times (\theta + 273.15)} \quad 2$$

Where: $p_v = \varphi e^{\left\{ 59.484085 - \left(\frac{6790.4985}{\theta + 273.15} \right) - 5.02802 [\ln(\theta + 273.15)] \right\}}$

and, φ can be taken as 0.5 (i.e. 50% relative humidity)

A.1.3 Correction for actual and observed airflow through the measuring device

The actual flow rate Q_m through the fan is a function of the measured values at the last fan calibration and measured values during the air test.

$$Q_m = Q_c \frac{\rho_c}{\rho_m} \quad 3$$

Where Q_m is the actual volumetric flow rate through the fan during the test, Q_c is the airflow rate from the last calibration of the fan, ρ_m is the density of air passing through the fan during the test (kg.m^{-3}) and ρ_c is the air density recorded during fan calibration.

A.1.4 Correction for internal/external air density differences

A correction is required for the internal/external density differences between air passing through the airflow measuring device and air passing through the building envelope. The correction to be applied depends on whether the building is being pressurised or depressurised.

A.1.4.1 Corrections to airflow rate for **pressurisation** tests:

Convert the measured airflow rate, Q_m to airflow through the building envelope, $Q_{env(out)}$, for pressurisation using equation 4:

$$Q_{env(out)} = Q_m \frac{\rho_e}{\rho_i} \quad 4$$

Where $Q_{env(out)}$ is the actual air flow volume out through the envelope, ρ_e is the mean external air density (kg.m^{-3}) and ρ_i is the mean internal air density (kg.m^{-3}).

A.1.4.2 Corrections to airflow rate for **depressurisation** tests:

Convert the measured airflow rate, Q_m , to airflow through the building envelope, $Q_{env(in)}$, for depressurisation using equation 5:

$$Q_{env(in)} = Q_m \frac{\rho_i}{\rho_e} \quad 5$$

Where $Q_{env(in)}$ is the actual air flow volume in through the envelope, ρ_e is the mean external air density (kg.m^{-3}) and ρ_i is the mean internal air density (kg.m^{-3}).

A.1.5 Determination of constants C and n using a least squares technique

The results from a steady state building test will give a dataset comprising of building pressure differentials (Δp_{env}) and corresponding air flow through the envelope (Q_{env}). There are several curve fitting approximations available to produce a best-fit line between these points. The most straightforward of these is the least squares approximation.

$$y = mx + b$$

Where:

$$\begin{aligned} y &= \ln(Q_{env}) \\ x &= \ln(\Delta p_{env}) \end{aligned}$$

The points recorded are fitted through the points $(x_1, y_1), \dots, (x_i, y_i)$ so that the sum of the squares of the distances of those points from the straight line is minimised. The airflow rates and corresponding building pressure differentials are plotted on a log-log graph for pressurisation and depressurisation as required.

The calculation of the factors m and b for a given (de)pressurisation test are as follows:-

$$d \sum XY = \sum (\ln[\Delta p_{env}] \times \ln[Q_{env}]) \quad 6$$

$$d \sum XX = \sum (\ln[\Delta p_{env}] \times \ln[\Delta p_{env}]) \quad 7$$

$$d \sum YY = \sum (\ln[Q_{env}] \times \ln[Q_{env}]) \quad 8$$

$$d \sum X = \sum \ln[\Delta p_{env}] \quad 9$$

$$d \sum Y = \sum \ln[Q_{env}] \quad 10$$

$$m = \frac{(d \sum X \times d \sum Y) - (i \times d \sum XY)}{(d \sum X \times d \sum X) - (i \times d \sum XX)} \quad 11$$

Where:

i = number of data points

$$b = \frac{(d \sum X \times d \sum XY) - (d \sum XX \times d \sum Y)}{(d \sum X \times d \sum X) - (i \times d \sum XX)} \quad 12$$

from this the air flow coefficient, C_{env} , and air flow exponent, n , are obtained:

$$C_{env} = e^b \quad 13$$

and

$$n = m \quad 14$$

A.1.6 Correction of airflow rates through the building envelope to standard temperature and pressure

The relationship is established between volumetric flow rate through the envelope and the induced building pressure differential:

$$Q_{env} = C_{env} \times \Delta p_{env}^n \quad 15$$

Where Q_{env} is the air flow rate through the building envelope ($m^3 \cdot h^{-1}$) and Δp_{env} is the induced building pressure differential, in Pa.

The air leakage coefficient, C_L , is obtained by correcting the air flow coefficient, C_{env} , to standard conditions (*i.e.* 20 °C and 101,325 Pa).

For **pressurisation** use equation:

$$C_L = C_{env} \times \left(\frac{\rho_i}{\rho_s}\right)^{1-n} \quad 16$$

For **depressurisation** use equation:

$$C_L = C_{env} \times \left(\frac{\rho_e}{\rho_s}\right)^{1-n} \quad 17$$

Where ρ_i is the indoor air density ($\text{kg}\cdot\text{m}^{-3}$), ρ_e is the outdoor air density ($\text{kg}\cdot\text{m}^{-3}$) and ρ_s is the air density at standard conditions ($\text{kg}\cdot\text{m}^{-3}$)

The air leakage rate, $Q_{\Delta p_{env}}$, for a given building pressure differential, Δp_{env} , can be calculated using equation:

$$Q_{\Delta p_{env}} = C_L \times (\Delta p_{env})^n \quad 18$$

Where C_L is the air leakage coefficient, in $\text{m}^3\cdot\text{h}^{-1}\cdot\text{Pa}^n$, Δp_{env} is the induced building pressure differential (Pa) and n is the air flow exponent.

A.1.7 Air permeability

The air permeability, AP_{50} , is the air leakage rate at a building pressure differential of 50 Pa, divided by the building envelope area A_E (m^2). Units are $\text{m}^3\cdot\text{h}^{-1}\cdot\text{m}^{-2}$. The air permeability is calculated using equation 19:

$$AP_{50} = \frac{Q_{50}}{A_E} \quad 19$$

Where $Q_{50} = C_L \times 50^n$, from equation 18.

A.1.8 Air Changes per Hour

The air change rate, N_{50} , is the air leakage rate at a building pressure differential of 50 Pa, divided by the building volume V (m^3). It defines the length of time required to completely change the volume of air within the building. Units are $\text{m}^3\cdot\text{h}^{-1}\cdot\text{m}^{-3}$. The air change is calculated using equation 19:

$$N_{50} = \frac{Q_{50}}{V} \quad 20$$

Where $Q_{50} = C_L \times 50^n$, from equation 20.

A.1.9 Coefficient of Determination (r^2)

The coefficient of determination (r^2) is a measure of the strength of the relationship between the observed building differential (Δp_{env}) and corresponding fan flow rates.

$$r^2 = \left(\frac{S_{xy}}{\sqrt{\sigma^2}} \right)^2$$

21

Where:

$$\sigma^2 = [(i \times d \sum XX) - (d \sum X \times d \sum X)] \times [(i \times d \sum YY) - (d \sum Y \times d \sum Y)]$$

$$S_{xy} = (i \times d \sum XY) - (d \sum X \times d \sum Y)$$

Appendix B – Technical Validity

B.1.1 Zero-flow pressure differences

A minimum of 10 readings shall be recorded both before and after test with each set of readings being recorded over a minimum of 30 seconds.

If any of the average zero flow pressure differences ($\Delta P_{0,1}$, $\Delta P_{0,1+}$, $\Delta P_{0,1-}$, $\Delta P_{0,2}$, $\Delta P_{0,2+}$ and $\Delta P_{0,2-}$), are found to be more than ± 5 Pa, conditions are not suitable to undertake a valid test, and the client should be advised.

B.1.2 Building pressure differentials

Due to the instability of building pressure differentials at lower levels, the minimum measured and corrected building pressure differentials must be the greater of 10 Pa, or five times the maximum average zero flow pressure difference measured prior to the test (the greater of $\Delta P_{0,1+}$, $\Delta P_{0,1-}$).

Building pressure differential readings shall not be taken above 90 Pa as this may over pressurise the building and present a risk to internal finishes, the fabric of the building and temporary seals applied.

The highest building pressure differential (measured and corrected) must be greater than 50 Pa. If the highest building pressure differential achieved is less than 50 Pa, the test is not valid. Building pressure differentials taken at low pressures will be more adversely affected by environmental conditions and any conclusions drawn from such a report should be treated with caution.

Measured and corrected building pressure differentials shall be taken both above and below 50 Pa.

A minimum of 7 building pressure differential measurements must be taken, with intervals between pressures being no greater than 10 Pa. It is recommended that 10 building pressure differentials are recorded. When the difference between the lowest and highest zero flow differences recorded before the test are greater than 10 Pa a minimum of 10 building pressure differential measurements shall be recorded.

When a uniform building pressure check is undertaken the building pressure differentials shall be within $\pm 10\%$ of the building pressure differential recorded from the geometric centre of the building. Additional information on ways to remedy readings in excess of this can be found in [Section 3.5](#).

B.1.3 Coefficient of Determination (r^2)

The coefficient of determination, or r^2 , is indicative of the accuracy with which a curve fitting equation can be applied to a set of results. For a building air tightness test an r^2 value of greater than 0.980 must be obtained. Test results that do not attain this minimum standard figure shall be declared not valid and this may be due to adverse environmental conditions or substandard test and data collection techniques.

B.1.4 Air flow exponent (n)

The air leakage paths through a building envelope under test will consist of several cracks and holes of varying shapes and size. The constants C and n are derived from the power law relationship. The air flow exponent, n , is used to describe the airflow regime through this orifice. Values should range between 0.5 and 1.0. If the value of n is not within these limits, then the test is not valid and should be repeated.

For information, n values which approach 0.5 will have fully developed turbulent flow through the building elements and represents air flow through rather large apertures, which tend to be indicative of rather leaky structures. Values of n which approach 1.0, will indicate a more laminar like flow through the building elements and generally represent very tight structures, or those with a myriad of very tiny holes, or convoluted air leakage paths.

Appendix C - Test Equipment Requirements

C.1.0 Introduction

The requirements for the accuracy of measurements are based primarily around BS EN ISO 9972:2015 - 'Thermal performance of buildings - Determination of air permeability of buildings - Fan pressurization method'.

Any readings taken outside of the calibrated ranges of the instruments shall not form part of the test data and may require the test to be undertaken again.

C.2.0 Accuracy

The following is a list of the required measurements and tolerances:

C.2.1 Building Pressure Differential Measurement (*micromanometer*)

An instrument capable of measuring pressure differentials with an accuracy of ± 2 Pa in the range of -100 to 100 Pa. *Note: ISO 9972:2015 states that the pressure measuring device is capable of measuring pressure with an accuracy of ± 1 Pa in the range of 0 Pa to 100 Pa.*

C.2.2 Air Flow Rate Measurement

The device must measure the air flow rate to within $\pm 7\%$ of the reading. The reading of the air flow rate shall be corrected according to air density in accordance with [Section A.1.3](#).

C.2.3 Temperature Measurement devices

The accuracy of temperature measurement must have an accuracy of ± 1.0 °C within the range of -20.0 to 40.0 °C. *Note: ISO 9972:2015 states that the temperature measuring device is capable of measuring temperature with an accuracy of ± 0.5 K.*

C.2.4 Barometric Pressure

A barometer must have an accuracy of ± 5 hPA in the range 950 - 1050 hPA.

C.3.0 Resolution

The resolution of an instrument is a factor which contributes to uncertainty in a measurement. It is therefore a consideration when selecting the suitability of an instrument used for testing. *i.e. for a micromanometer, which is used to measure zero flow pressures typically in the range of ± 5 Pa, must have a resolution of 0.1 Pa rather than 1 Pa as the resolution uncertainty is 0.05 Pa rather than 0.5 Pa.*

C.4.0 Calibration

All instrumentation must be calibrated in accordance with national requirements to the following specification by a laboratory that is accredited by a national accreditation body that is a signatory of the ILAC mutual recognition arrangement. All calibration certificates must bear the logo of the accreditation body, with laboratory number, and ILAC logo to be considered acceptable. Note that a confirmation of performance is not compliant and cannot be treated as such.

The flow measurement device will require to be calibrated against a recognised test procedure. Such test procedures will have to satisfy national requirements.

There are two standards worthy of reference, BS ISO 3966:2020 'Measurement of fluid flow in closed conduits. Velocity area method using Pitot static tubes' and BS 848-1:1997 (ISO 5801:2017) 'Industrial fans. Performance testing using standardized airways', or later.

It will also be a requirement for companies accredited through national accreditation schemes to calculate estimates of uncertainty for not only the individual parameters but also a final uncertainty budget from the square root of the sum of the squares of the standard deviation of each source of uncertainty.

Appendix D - Equivalent Leakage Area (ELA)

D.1.0 Approximate leakage surface area

It is often useful for the test engineer to translate the results of an air tightness test into a more readily understandable form such as an equivalent leakage area, A (m^2). Area of 'holes' left in the structure can be a useful guide, but it is only an aerodynamic equivalent area based on a sharp-edged orifice and should therefore be regarded as approximate.

The flow rate of air can be expressed by:

$$Q_{\Delta p_{env}} = C_d \times A \times \left(\frac{2 \times \Delta p_{env}}{\rho_s} \right)^n \quad 22$$

Where:

The discharge coefficient, C_d for a sharp-edged orifice can be taken as 0.61, standard air density ρ_s is taken as 1.20 kg.m^{-3} , n can be taken as 0.5, the test pressure is 50 Pa, and Q_{50} is in $\text{m}^3.\text{s}^{-1}$, which allows equation to be simplified and rearranged to:

$$A = \frac{Q_{50}}{5.57} \quad 23$$

Most buildings do not exhibit an air flow exponent (n) of 0.5 because the air leakage paths can be long and convoluted, etc. and as such the above equation is only approximate.

The above should be treated with extreme caution since 'holes' in buildings tend to look considerably larger than they actually are, since the other side of the 'hole' may have a tortuous exit route or be occluded by a hidden membrane.

The equivalent leakage area must only be used as a guide for remedial measures and not to determine the final air permeability value.

Appendix E – Software verification process

E.1.0 Introduction

To verify custom test software, the following readings and calibration data have been provided, along with the result. This can provide a method of checking that the software is working, particularly after software upgrades, this data shall be entered, and the result verified. If this test data is inappropriate for checking new/upgraded software, then the software algorithms should be checked manually using a different method such as a spreadsheet or by hand.

E.2.0 Data – Fan Calibration

Static Pressure (Pa)	Flow Pressure (Pa)	Volume Flow (m ³ .s ⁻¹)	Exponent	Coefficient (m ³ .s ⁻¹)
-50.5	260.2	1.2803	0.482111	0.087691
-50.5	175.4	1.0589		
-50.6	133.3	0.9278		
-50.2	90.9	0.7713		
-50.3	50.4	0.5803		

Calibration Air Density for Volume Flow (kg.m⁻³)

1.200

E.3.0 Test Data – Common to All Methods

Building Tested Details	
Envelope Area	367.0 m ²
Volume	332.0 m ³

Environmental Readings	Before	After
Temperature Internal (°C)	15.0	13.0
Temperature External (°C)	10.0	10.0
Barometric Pressure (Pa)	99400	99400

Zero Flow Pressure Readings (Pa)										
Before	0.6	0.4	0.3	0.1	-0.6	0.6	0.0	0.1	0.0	0.2
After	0.8	1.4	2.0	1.2	0.4	2.4	1.6	1.4	1.8	0.8

Zero Flow Pressure Averages	Before ($\Delta P_{0,1}$)	After ($\Delta P_{0,2}$)
Positive Readings	0.33	1.38
Negative Readings	-0.60	0.00
All Readings	0.17	1.38

E.4.0 Data – Pressurisation Test

Test Type	Channel A		Channel B	
	Input +	Ref -	Input +	Ref -
Pressurise	○ Inside	○ Outside	○ Fan	○ Outside
	Building Pressure (+)		Flow Pressure (-)	

Reading	Building Pressure (Pa)	Flow Pressure (Pa)	Corrected Flow $Q_{env(out)}$ ($m^3 \cdot h^{-1}$)
1	57.4	-245.0	4,470
2	56.9	-232.0	4,354
3	52.6	-227.0	4,308
4	50.6	-211.0	4,159
5	49.5	-201.5	4,068
6	46.1	-187.0	3,924
7	40.6	-153.0	3,562
8	34.7	-130.0	3,293
9	30.7	-108.0	3,012
10	25.1	-91.0	2,773

Results	
Air Flow Coefficient (C_{env})	425.45 $m^3 \cdot h^{-1} \cdot Pa^n$
Air Leakage Coefficient (C_L)	425.96 $m^3 \cdot h^{-1} \cdot Pa^n$
Air Flow Exponent (n)	0.581
Coefficient of Determination (r^2)	0.993
Flow at 50 Pa (Q_{50})	4,141 $m^3 \cdot h^{-1}$

Air Permeability (AP_{50})	11.28 ($\pm 0.2\%$)
Air Changes Per Hour (N_{50})	12.47 ($\pm 0.2\%$)

E.5.0 Data – Depressurisation Test

Test Type	Channel A		Channel B	
	Input +	Ref -	Input +	Ref -
Depressurise	○ Inside	○ Outside	○ Fan	○ Inside
	Building Pressure (-)		Flow Pressure (-)	

Reading	Building Pressure (Pa)	Flow Pressure (Pa)	Corrected Flow $Q_{env(in)}$ ($m^3 \cdot h^{-1}$)
1	-74.0	-252.1	4,466
2	-69.2	-240.5	4,365
3	-64.3	-220.0	4,182
4	-59.7	-195.0	3,945
5	-56.2	-172.4	3,718
6	-50.7	-162.0	3,608
7	-45.3	-123.0	3,159
8	-41.4	-124.0	3,172
9	-36.1	-100.7	2,869
10	-32.9	-87.0	2,674

Results	
Air Flow Coefficient (C_{env})	$270.10 m^3 \cdot h^{-1} \cdot Pa^n$
Air Leakage Coefficient (C_L)	$271.75 m^3 \cdot h^{-1} \cdot Pa^n$
Air Flow Exponent (n)	0.653
Coefficient of Determination (r^2)	0.989
Flow at 50 Pa (Q_{50})	$3,494 m^3 \cdot h^{-1}$

Air Permeability (AP_{50})	9.52 ($\pm 0.2\%$)
Air Changes Per Hour (N_{50})	10.53 ($\pm 0.2\%$)

Appendix F – Checklists

F.1.0 Building Condition Requirements

Step	Description	Completed?
1	All drainage traps are filled with water.	
2	Incoming or outgoing service penetrations have been made and have permanent sealing works completed around the penetrations.	
3	External doors, including integral garage doors, are fitted with seals and closed as necessary.	
4	External windows are fitted with seals and closed as necessary.	
5	Electrical items such sockets must be fitted to the wall without items plugged in, other than for the operation of the fan pressurisation system.	
6	Light switches shall be fitted to the wall.	
7	Lighting shall be fitted in the ceilings.	
8	Internal doors are restrained open and remain open for the test.	
9	Heating systems shall be installed.	
10	Ventilation systems shall be installed.	
11	Kitchen units shall be installed	